

SUPPORTING DOCUMENT 1

APPLICATION A1042 – FOOD DERIVED FROM HERBICIDE-TOLERANT CORN LINE DAS-40278-9

Safety Assessment Report

SUMMARY AND CONCLUSIONS

Background

Herbicide-tolerant corn line DAS-40278-9 has been genetically modified (GM) for tolerance to 2,4-dichlorophenoxyacetic acid (2,4-D) and aryloxyphenoxypropionate (AOPP) acetyl coenzyme A carboxylase (ACCase) inhibitors (so-called “fop” herbicides) such as quizalofop-P-ethyl. This has been achieved through the introduction of the *aad-1* gene, from *Sphingobium herbicidovorans*, expressing the enzyme aryloxyalkanoate dioxygenase (AAD-1).

In conducting a safety assessment of food derived from herbicide-tolerant corn line DAS-40278-9, a number of criteria have been addressed including: a characterisation of the transferred gene, its origin, function and stability in the corn genome; the changes at the level of DNA, protein and in the whole food; compositional analyses; evaluation of intended and unintended changes; and the potential for the newly expressed protein to be either allergenic or toxic in humans.

This safety assessment report addresses only food safety and nutritional issues. It therefore does not address: environmental risks related to the environmental release of GM plants used in food production; the safety of animal feed or animals fed with feed derived from GM plants; or the safety of food derived from the non-GM (conventional) plant.

History of Use

Corn is the world’s third leading cereal crop, behind wheat and rice, and is grown in over 25 countries. Corn-derived products are routinely used in a large number and diverse range of foods and have a long history of safe use. Products derived from DAS-40278-9 corn may include flour, starch products, breakfast cereals and high fructose corn syrup. Corn is also widely used as a feed for domestic livestock.

S. herbicidovorans, the donor organism for the *aad-1* gene, is a common gram-negative soil bacterium. Species within the genus have a wide distribution in nature, and therefore have a significant exposure level in both animals and humans. Sphingomonads have been used in many biotechnological applications, where their biodegradative and biosynthetic capabilities are exploited.

Molecular Characterisation

Corn DAS-40278-9 was generated through the transfer of the *aad-1* gene under the control of the *Zea mays* ZmUbi1 promoter. This promoter directs constitutive expression in corn tissues. The *aad-1* gene encodes AAD-1, consisting of 296 amino acids with a molecular weight of 33 kDa. The protein sequence is >99% identical to the AAD-1 protein from *Sphingobium herbicidovorans*.

There are no antibiotic-resistance marker genes in corn DAS-40278-9.

Comprehensive molecular analyses of corn DAS-40278-9 indicate there is one insertion site at a single genetic locus. This site contains one copy of the *aad-1* gene. Breeding over ten lines/generations has confirmed stability of the introduced genetic elements and segregation data indicate their Mendelian inheritance.

Characterisation of Novel Protein

Corn DAS-40278-9 expresses one novel protein, AAD-1. It is expressed in leaves, pollen, roots, grain and forage. The average content in mature grain is 4.8 µg/g dry weight (range 1.07-9.10 µg/g).

Several studies were undertaken to confirm the identity and physicochemical and functional properties of AAD-1 as well as to determine its potential toxicity and allergenicity. These studies have demonstrated that AAD-1 conforms in size and amino acid sequence to that expected and does not exhibit any post-translational modification including glycosylation.

The AAD-1 protein was investigated for its potential to be a toxin or allergen. Bioinformatic studies with the AAD-1 protein have confirmed the absence of any biologically significant amino acid sequence similarity to known protein toxins or allergens and digestibility studies have demonstrated that the protein would be rapidly degraded following ingestion, similar to other dietary proteins. Taken together, the evidence indicates that the AAD-1 protein is neither toxic nor likely to be allergenic in humans.

Herbicide Metabolites

The major residues generated on corn line DAS-40278-9 as a result of spraying with 2,4-D and quizalofop-P-ethyl are not novel. The residues are the same as those found on conventional crops. Residue data derived from supervised trials indicate that the residue levels for both herbicides are below the limit of quantitation. In the absence of any measurable exposure to either parent herbicide or their metabolites the risk to public health and safety is likely to be negligible.

Compositional Analyses

Detailed compositional analyses were done to establish the nutritional adequacy of grain-derived products from corn DAS-40278-9. Grain was analysed for proximates (ash, total fat, moisture, protein and carbohydrates), fibre (total dietary fibre, acid detergent fibre (ADF), neutral detergent fibre (NDF)), minerals, amino acids, fatty acids (C8-C22), vitamins, secondary metabolites and anti-nutrients. Compositional analysis was undertaken on unsprayed corn, corn sprayed with 2,4-D, corn sprayed with quizalofop-P-ethyl and corn sprayed with both 2,4-D and quizalofop-P-ethyl. The levels were compared with levels in the near-isogenic control corn. These analyses indicated that although several variables differed significantly from the control, no biologically meaningful differences occurred.

The compositional data are consistent with the conclusion that there are no relevant significant differences in the levels of key components in seed from corn DAS-40278-9 when compared with conventional corn cultivars currently on the market.

Nutritional Impact

The detailed compositional studies are considered sufficient to establish the nutritional adequacy of food derived from corn DAS-40278-9. No biologically significant differences in the nutritional content between DAS-40278-9 and non-GM corn varieties could be established. As such, the introduction of corn DAS-40278-9 into the food supply would be expected to have little nutritional impact.

Conclusion

No potential public health and safety concerns have been identified in the assessment of insect-protected corn DAS-40278-9. On the basis of the data provided in the present application, and other available information, food derived from corn DAS-40278-9 is considered to be as safe for human consumption as food derived from conventional corn cultivars.

Table of Contents

BACKGROUND.....	I
HISTORY OF USE.....	I
MOLECULAR CHARACTERISATION.....	II
CHARACTERISATION OF NOVEL PROTEIN	II
COMPOSITIONAL ANALYSES	II
NUTRITIONAL IMPACT	III
CONCLUSION.....	III
List of Figures	3
List of Tables	3
1 INTRODUCTION.....	4
2 HISTORY OF USE.....	4
2.1 Donor organism.....	4
2.2 Host organism	4
3 MOLECULAR CHARACTERISATION.....	5
3.1 Method used in the genetic modification	6
3.2 Breeding of corn line DAS-40278-9	8
3.3 Function and regulation of introduced gene sequences	9
3.3.1 The aad-1 coding sequence.....	9
3.3.2 The aad-1 regulatory sequences.....	10
3.3.3 The matrix attachment regions (MARs).....	10
3.4 Characterisation of the genes in the plant.....	10
3.4.1 Transgene copy number	10
3.4.2 Plasmid backbone DNA analysis	11
3.4.3 Insertion site analysis	11
3.4.4 Open Reading Frame (ORF) analysis of the junction regions.....	11
3.4.5 Conclusion about gene characterisation	12
3.5 Stability of genetic changes	12
3.5.1 Generational stability	12
3.5.2 Segregation analysis	12
3.5.3 Conclusion about the stability of the genetic change	13
3.6 Antibiotic resistance marker genes	13
3.7 Conclusion about molecular characterisation	14
4 CHARACTERISATION OF NOVEL PROTEINS.....	14
4.1 Description and function of the novel protein	14
4.2 Identification of the AAD-1 protein and equivalence of DAS-40278-9-produced and <i>P. fluorescens</i> -produced AAD-1 protein.....	15

4.2.1	Molecular weight	16
4.2.2	Amino acid sequence	16
4.2.3	Glycosylation analysis	17
4.2.4	Conclusion.....	17
4.3	AAD-1 protein expression analysis	18
4.4	Potential toxicity of the AAD-1 protein.....	19
4.4.1	History of human consumption.....	19
4.4.2	Structural similarity of AAD-1 to known toxins.....	20
4.4.3	Acute oral toxicity study.....	20
4.5	Potential allergenicity of the AAD-1 protein.....	21
4.5.1	Source of protein	21
4.5.2	Similarity to known allergens.....	21
4.5.3	In vitro digestibility	22
4.6	Conclusion from characterisation of novel protein	23
5	HERBICIDE METABOLITES.....	23
5.1	Residue chemistry studies	24
5.2	ADI for 2,4-D and quizalofop-P-ethyl	24
5.3	Conclusion	25
6	COMPOSITIONAL ANALYSES	25
6.1	Key components	25
6.2	Study design and conduct for key components	26
6.3	Analyses of key components	27
6.3.1	Proximates and fibre	27
6.3.2	Minerals.....	28
6.3.3	Amino Acids	29
6.3.4	Fatty Acids.....	30
6.3.5	Vitamins.....	32
6.3.6	Secondary metabolites.....	32
6.3.7	Anti-nutrients	33
6.4	Conclusion from compositional studies.....	33
7	NUTRITIONAL IMPACT	34
	REFERENCES	34

List of Figures

Figure 1: The corn wet milling process	5
Figure 2: Schematic map of plasmid pDAS1740 including Fsp1 restriction sites used for transformation of corn via Whisker-mediated transformation.	6
Figure 3: Schematic of the development of DAS-40278-9 corn.....	7
Figure 4: Breeding diagram for DAS-40278-9 corn from original transformant to commercialised hybrid.	8
Figure 5: Schematic map of the inserted <i>aad-1</i> cassette, the restriction sites within the cassette and the expected fragments resulting from digestion with NcoI.	13
Figure 6: General representation of the conversion of pyridyloxyacetate and phenoxyacetate herbicides to an inactive phenol in the presence of AAD-1.	15
Figure 7: Metabolism of quizalofop-P-ethyl to quizalofop phenol by AAD-1	15

List of Tables

Table 1: Description of the genetic elements contained in the FspI fragment of plasmid pDAS1740.....	9
Table 2: Location and length of probes used in the Southern blot analysis.....	10
Table 3: Tissues collected for AAD-1 expression level analysis	18
Table 4: Summary of mean concentration levels of AAD-1 protein measured in AAD-1 unsprayed, AAD-1 + Quizalofop-P-ethyl, AAD-1 + 2,4-D and AAD-1 + Quizalofop-P-ethyl and 2,4-D in corn tissues	18
Table 5: Residue levels in grain of corn line DAS-40278-9 sprayed with 2,4-D and quizalofop-P-ethyl (data from Culligan (2010) – see Studies submitted)	24
Table 6: Statistical summary of combined-site corn grain proximate and fibre content.....	27
Table 7: Statistical summary of combined-site corn grain mineral content.....	28
Table 8: Statistical summary of combined-site corn grain amino acid content	29
Table 9: Statistical summary of combined-site corn grain fatty acid content	30
Table 10: Statistical summary of combined-site corn grain vitamin content	32
Table 11: Statistical summary of combined-site corn grain secondary metabolite content...	33
Table 12: Statistical summary of combined-site corn grain anti-nutrient content.....	33

1 INTRODUCTION

Dow AgroSciences Australia Limited has submitted an application to FSANZ to vary Standard 1.5.2 – Food produced using Gene Technology – in the *Australia New Zealand Food Standards Code* (the Code) to include food from a new genetically modified (GM) corn line, DAS-40278-9. The corn has been modified to be tolerant to 2,4-dichlorophenoxyacetic acid (2,4-D) and aryloxyphenoxypropionate (AOPP) acetyl coenzyme A carboxylase inhibitors (“fop” herbicides) such as quizalofop-P-ethyl.

Tolerance to these herbicides is conferred by expression in the plant of the *aad-1* gene, encoding aryloxyalkanoate dioxygenase (AAD-1), which inactivates herbicides having a common aryloxyalkanoate structure. The *aad-1* gene is derived from *Sphingobium herbicidovorans*, a common soil bacterium.

Corn is not a major crop in Australia or New Zealand. Domestic production is supplemented by the import of a small amount of corn-based products, largely as high-fructose corn syrup, which is not currently manufactured in either Australia or New Zealand. Such products are processed into breakfast cereals, baking products, extruded confectionery and food coatings. In 2007, Australia imported 529 tonnes of corn, 4613 tonnes of corn flour and 2263 tonnes of corn oil; no forage or silage were imported (FAOSTAT 2010).

Other corn products such as cornstarch are also imported and used by the food industry for the manufacture of dessert mixes and sauces. Corn may also be imported in finished products such as corn chips and canned corn.

DAS-40278-9 corn will be grown in North America and is not intended for cultivation in Australia or New Zealand. Therefore, if approved, food from this line may enter the Australian and New Zealand food supply as imported food products.

2 HISTORY OF USE

2.1 Donor organism

The organism from which the *aad-1* gene is derived is the common soil bacterium, *Sphingobium herbicidovorans*. The *Sphingobium* genus is part of a larger group of bacteria called Sphingomonads, which are found commonly in nature, including associated with food products such as fermented milk (Bauer et al. 2009), rice (Videira et al. 2010), corn (Rijavec et al. 2007), papaya (Thomas et al. 2007) and tomato (Enya et al. 2007), among others. Members of the *Sphingobium* genus are also commonly used in the food industry (Pozo et al. 2007; Fialho et al. 2008) and in bioremediation (Alarcon et al. 2008).

Sphingobium herbicidovorans is a strictly aerobic, gram-negative, non-sporulating, yellow-pigmented bacterium that can utilise phenoxy auxin and AOPP herbicides as carbon sources (Zipper et al. 1996; Takeuchi et al. 2001). It is not known to be associated with human disease.

2.2 Host organism

Corn is the world's third leading cereal crop, behind wheat and rice, and is grown in over 25 countries (OECD 2002). In 2008, worldwide production of corn was over 800 million tonnes, with the United States and China being the major producers (~300 and 170 million tonnes, respectively) (FAOSTAT, 2010).

The majority of grain and forage derived from corn is used as animal feed, however corn also has a long history of safe use as food for human consumption. There are five main types of corn grown for food (flour, flint, dent, sweet and pop) of which dent corn is the most commonly grown for grain and silage and is the predominant type grown in the U.S. (OGTR 2008). Two main grain processing routes are followed (White and Pollak 1995):

- Dry milling that gives rise to food by-products such as flour and hominy grits.
- Wet milling (CRA 2006), that involves steeping the grain, coarse and fine grinding, centrifugation and evaporating the steep, to yield food by-products such as starch (for cornstarch, corn syrup and individual sweeteners such as dextrose and fructose) and germ (for oil) – see Figure 1. Corn products are used widely in processed foods.

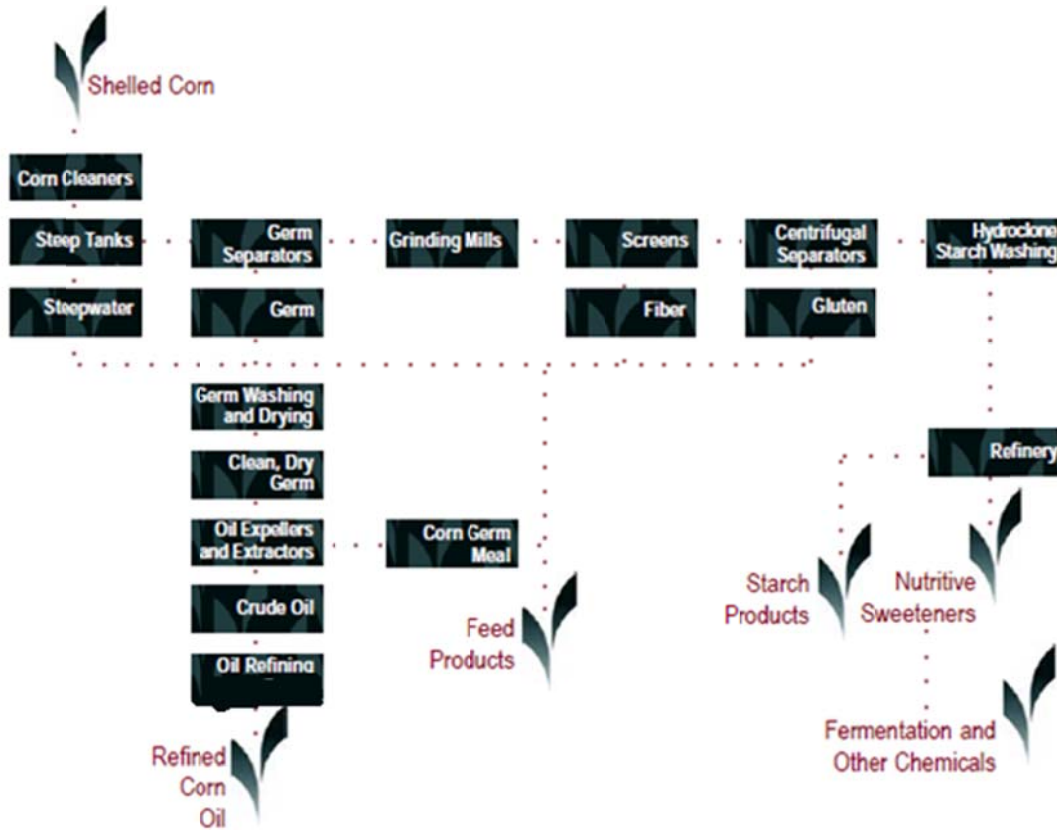

Figure 1: The corn wet milling process (diagram taken from CRA (2006))

Corn plants usually reproduce sexually by wind-pollination. This provides for natural out-crossing between plants, but it also presents an opportunity for plant breeders to produce hybrid seed by controlling the pollination process. Open pollination of hybrids in the field leads to the production of grain with properties derived from different lines and, if planted, could produce lower yields (CFIA 1994). The commercial production of corn now utilises controlled cross-pollination of two inbred lines (using conventional techniques) to combine desired genetic traits and produce hybrid varieties known to be superior to open-pollinated varieties in terms of their agronomic characteristics. This inbred-hybrid concept and resulting yield response is the basis of the modern corn seed industry and hybrid corn varieties are used in most developed countries for consistency of performance and production.

3 MOLECULAR CHARACTERISATION

Molecular characterisation is necessary to provide an understanding of the genetic material introduced into the host genome and helps to frame the subsequent parts of the safety

assessment. The molecular characterisation addresses three main aspects: the transformation method together with a detailed description of the DNA sequences introduced to the host genome; a characterisation of the inserted DNA including any rearrangements that may have occurred as a consequence of the transformation; and the genetic stability of the inserted DNA and any accompanying expressed traits.

Studies submitted:

M. Zhuang, J. Mo, J.D. Poorbaugh, K.A. Richey, J. Cruse, A. Thomas. (2009). Molecular characterization of AAD-1 corn event DAS-40278-9. Dow AgroSciences LLC Study Report 081052.

M. Zhuang, J.D. Poorbaugh, J. Mo, K.A. Richey, J. Cruse, A. Thomas. (2009). Molecular characterization of AAD-1 corn event DAS-40278-9 within a single generation. Dow AgroSciences LLC Study Report 081120.

Mo, J.; Zhou, N.; Poorbaugh, J. (2009). Cloning and characterization of DNA sequence in the insert and the flanking border regions of AAD-1 corn event DAS-40278-9. Dow AgroSciences LLC Study Report 091023.

P. Song. (2010). Bioinformatics analysis of maize event DAS-40278-9 insert and its flanking border sequences. Dow AgroSciences LLC Study Report 101708.

P. Song. (2010). Bioinformatics evaluation of the putative reading frames across the junction in maize event DAS-40278-9 for potential protein allergenicity and toxicity. Dow AgroSciences LLC Study 101709.

3.1 Method used in the genetic modification

Corn cultivar Hi-II was transformed with the FspI fragment of plasmid pDAS1740 (see Figure 2). This fragment contains the matrix attachment regions (MARs) v3 and v4 of *Nicotiana tabacum*, the ZmUbi1 ubiquitin promoter from *Z. mays*, the *aad-1* gene from *S. herbicidovorans* and the ZmPer5 3' UTR (terminator region) from the *Z. mays* peroxidase gene. The bacterial origin of replication and antibiotic resistance gene were removed by digestion with FspI and therefore were not transformed into the corn.

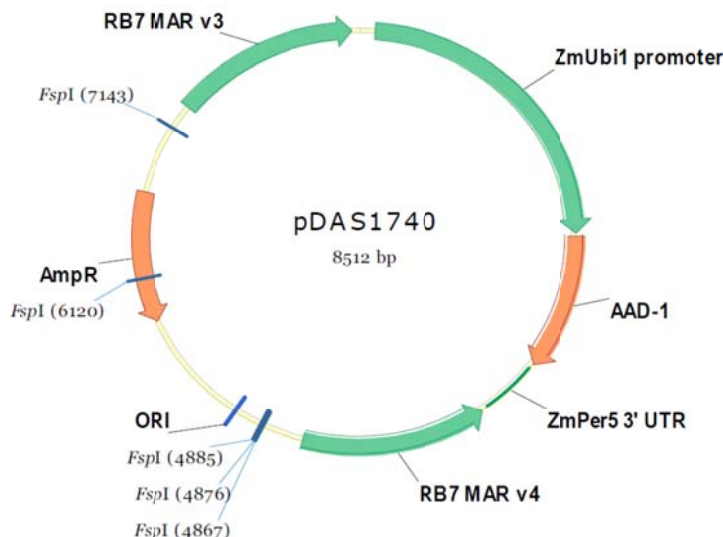

Figure 2: Schematic map of plasmid pDAS1740 including FspI restriction sites used for transformation of corn via Whisker-mediated transformation.

The genetic modification was carried out as follows: Suspension cultures of immature Hi-II corn embryos were agitated in the presence of pDAS1740 (*Fsp*I fragment) and silicon carbon whisker fibres to introduce the DNA into the cells. Selection for transformants took place by transfer to a medium containing the herbicide R-haloxyp (an AOPP herbicide). Callus samples containing the transgene and no plasmid backbone were used to regenerate whole transgenic plants. Tolerance to herbicides was confirmed via spraying with quizalofop-P-ethyl. Surviving plants were crossed with DAS elite inbred corn line XHH13. Further backcrossing and self-fertilisation, as well as crossing with DAS elite inbred corn line “inbred C” lead to the creation of the current line (see 3.2). One plant, event DAS-40278-9, was used for characterisation and commercialisation (see Figure 3).

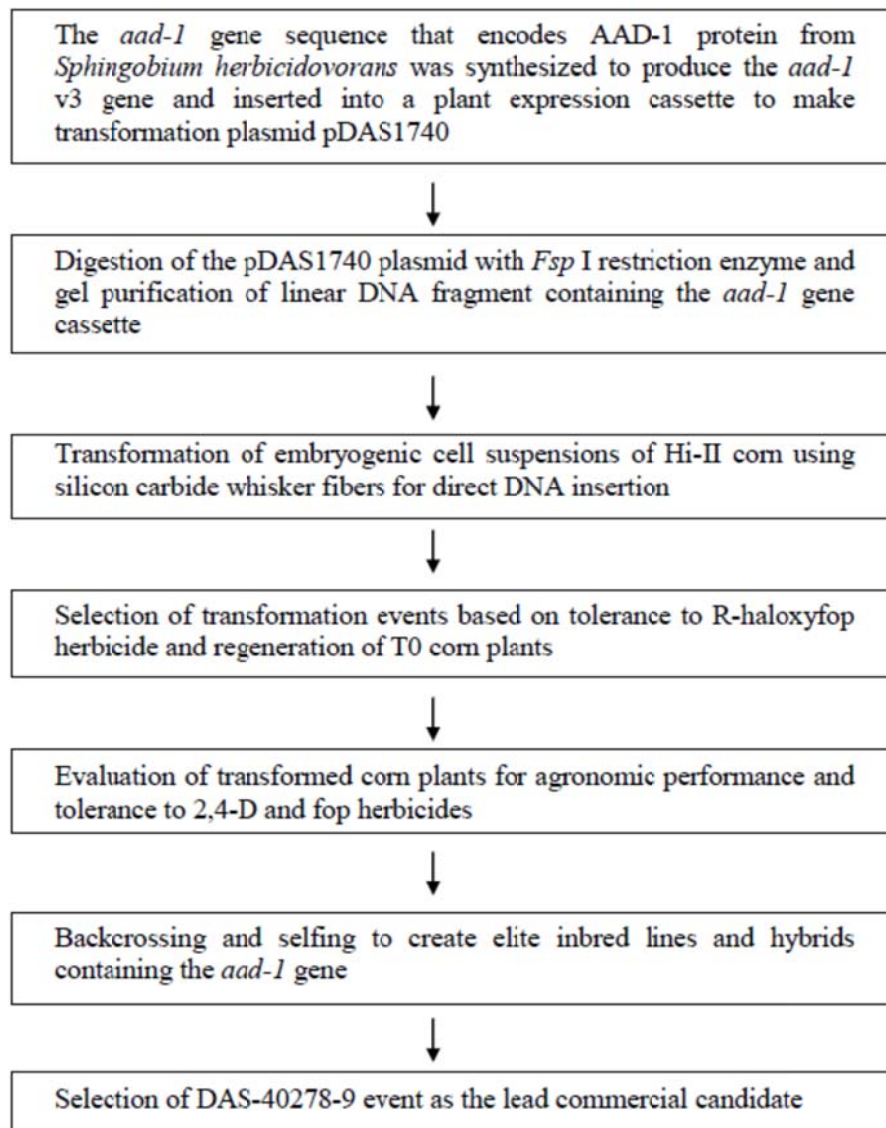
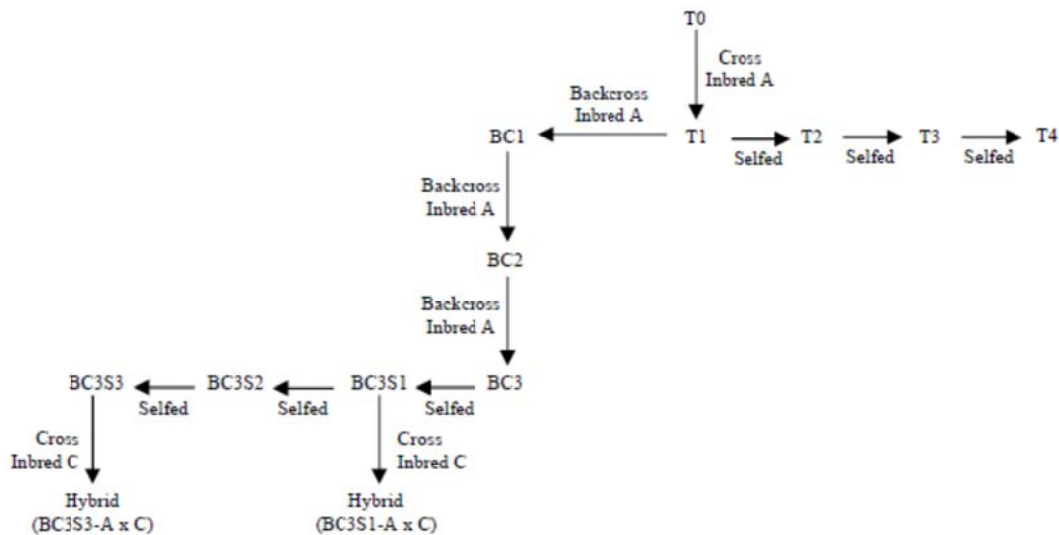

Figure 3: Schematic of the development of DAS-40278-9 corn.

3.2 Breeding of corn line DAS-40278-9

Figure 4 summarises how corn line DAS-40278-9 was produced from the Hi-II T0 transgenic line. T0 plants were crossed with DAS elite inbred line XHH13 (called “Inbred A”) to produce the T1 line. This line was backcrossed to XHH13 to produce BC1 (Back-Cross 1). Two further back-crossings produced the BC3 line, which was self-fertilised, resulting in BC3S1 (Back Cross 3, Self 1). This line was then crossed with an elite Dow AgroSciences proprietary inbred line referred to only as “Inbred C”. This resulted in the hybrid line BC3S1-AxC, out of which the DAS-40278-9 event was chosen for characterisation and commercialisation. Several other self-fertilisations were carried out (resulting in T2, T3 and T4) for analysis of genetic stability.



Inbred A = DAS elite inbred XHH13 Inbred C = DAS elite inbred used to make hybrid T0 = original transformant T1 = first generation, derived from cross of T0 with elite inbred T2 = derived from self-pollination of T1 T3 = derived from self-pollination of T2 T4 = derived from self-pollination of T3	BC1 = first backcross with elite parental inbred BC2 = second backcross with elite parental inbred BC3 = third backcross with elite parental inbred BC3S1 = derived from self-pollination of BC3 BC3S2 = derived from self-pollination of BC3S1 BC3S3 = derived from self-pollination of BC3S2 Hybrid = cross between two elite inbreds
---	---

Figure 4: Breeding diagram for DAS-40278-9 corn from original transformant to commercialised hybrid.

3.3 Function and regulation of introduced gene sequences

Information on the coding sequences, nucleotide sequences and regulatory elements in the linear FspI fragment from plasmid pDAS1740 is given in Table 1.

Table 1: Description of the genetic elements contained in the FspI fragment of plasmid pDAS1740

Location on FspI fragment	Genetic element	Size (base pairs)	Description
1-164	Intervening sequence	164 bp	Sequence from pUC19 (Yanisch-Perron et al. 1985)
165-1330	RB7 MAR v3	1166 bp	Matrix attachment region (MAR) from <i>Nicotiana tabacum</i> (Hall Jr et al. 1991)
1331-1459	Intervening sequences	129 bp	Sequence used for DNA cloning and sequence from pUC19 (Yanisch-Perron et al., 1985)
1460-3450	ZmUbi1 promoter	1991 bp	Ubiquitin promoter from <i>Zea mays</i> (Christensen et al. 1992)
3451-3472	Intervening sequence	22 bp	Sequences used for DNA cloning
3473-4363	<i>aad-1</i> gene	891	Synthetic, plant-optimised version of an aryloxyalkanoate dioxygenase gene from <i>Sphingobium herbicidovorans</i> (Wright et al. 2009)
4364-4397	Intervening sequence	34 bp	Sequence used for DNA cloning
4398-4762	ZmPer5 3' UTR	365 bp	3' untranslated region from <i>Zea mays</i> peroxidase gene (Ainley et al. 2002)
4763-4801	Intervening sequence	39 bp	Sequence used for DNA cloning
4802-5967	RB7 MAR v4	1166	Matrix attachment region (MAR) from <i>Nicotiana tabacum</i> (Hall Jr et al., 1991)
5968-6236	Intervening sequence	269 bp	Sequence from pUC19 (Yanisch-Perron et al., 1985)

3.3.1 The *aad-1* coding sequence

DAS-40278-9 carries a single copy of the *aad-1* gene. This gene encodes the AAD-1 protein, which is derived from the common soil bacterium *Sphingobium herbicidovorans*. The C+G content of the gene has been optimised for expression in plants. Additionally, an alanine codon has been added to encode an NcoI restriction enzyme site spanning the ATG translational start codon, thereby facilitating subsequent cloning operations and optimising

initiation of translation (Wright et al., 2009). This results in the addition of an alanine at position two of the protein.

Expression of the *aad-1* gene leads to tolerance to herbicides such as 2,4-D and AOPPs. The AAD-1 protein shares >99% homology with the *Sphingobium herbicidovorans* protein.

3.3.2 *The aad-1 regulatory sequences*

Expression of the *aad-1* gene is under the control of the ZmUbi1 promoter and ZmPer5 3' UTR. Both sequences are from *Z. mays* genes, the former from the ubiquitin gene and the latter from a peroxidase gene. The ZmUbi promoter drives constitutive expression of the genes it controls (Christensen and Quail 1996).

3.3.3 *The matrix attachment regions (MARs)*

The matrix attachment regions from *N. tabacum* are found on either end of the linear FspI DNA fragment. Their purpose is to increase expression of the *aad-1* gene in the plant. These regions have been found by several groups (Han et al. 1997; Verma et al. 2005; Abranches et al. 2005) to increase transgene expression while reducing transgene-induced gene silencing.

3.4 Characterisation of the genes in the plant

Evaluation of insert copy number, insert integrity and presence/absence of plasmid backbone sequences was done by Southern blot analysis of DAS-40278-9 genomic DNA. The line to which the original transgenic plants were backcrossed for three generations (XHH13) was chosen as the control. This was because the molecular characterisation was performed on several generations or lineages of the original event. Thus XHH13 is the closest to isogenic line for this event.

The probes used for the analysis cover virtually the entire plasmid pDAS1740. In this way, the various generations can be assessed not only for copy number, but also for the presence of the plasmid backbone. The names of the probes and their corresponding positions on the original plasmid are given in Table 2.

Table 2: Location and length of probes used in the Southern blot analysis

Probe	Position on pDAS1740	Length (bp)
ZmUbi1 promoter	28-2123	2096
<i>aad-1</i> gene	2103-3022	920
ZmPer5 terminator	3002-3397	396
RB7 Mar v4	3375-4865	1491
Backbone (OLP4A)	4900-5848	949
Backbone Ap ^r gene (OLP4B)	5828-6681	855
Backbone (OLP4C)	6660-7144	485
RB7 Mar v3	7124-8507	1384

3.4.1 *Transgene copy number*

Leaf tissue from individual seedlings of control plants (XHH13) and the T3, T4, BC3S1, BC3S2 and BC3S3 generations (see Figure 4) were used for analysis. In order to determine transgene copy number, genomic DNA was subjected to restriction digest and gel electrophoresis. The DNA was then transferred to a membrane and incubated with one of the above probes. As some restriction digests liberate fragments unique to each insertion (by utilising flanking genomic DNA restriction sites), and other digests liberate fragments internal to the inserted DNA, both the number of insertion sites and the copy number can be

established. Incorporation of the DNA into more than one site, or incorporation of more than one copy of the plasmid within the one site would result in additional bands.

Analysis of restricted genomic DNA by Southern blot demonstrated that one complete copy of the FspI fragment of pDAS1740 was inserted into the corn genome. The banding pattern was consistent only with a single insertion event. Genomic DNA from one plant (BC3S3-3) showed increased hybridisation (suggesting DNA overload) and thus retardation in the gel. Measurement of DNA concentration for this sample confirmed that the concentration of genomic DNA was higher than that for other samples. When this was corrected, the bands from digestion of BC3S3 in subsequent gels migrated identically to all other samples.

3.4.2 *Plasmid backbone DNA analysis*

In order to test for the presence of plasmid backbone in the DAS-40278-9 genome, leaf tissue was isolated, digested with restriction enzymes and subjected to gel electrophoresis as before. Three probes made from plasmid backbone regions (see Table 2) were hybridised to the digested genomic DNA.

None of the three probes hybridised with DNA in any of the DAS-40278-9 generations, or the near isogenic control (XHH13). Demonstration of the function of the probes was assured through hybridisation with “spiked” XHH13 (XHH13 DNA mixed with 1 copy of pDAS1740). These data demonstrate that the plasmid backbone is not present in DAS-40278-9.

3.4.3 *Insertion site analysis*

Genomic DNA from DAS-40278-9 corn was extracted and subjected to polymerase chain reaction (PCR) analysis. Primers were designed in order to establish the nucleotide sequence of the inserted DNA, as well as to determine the sequence of the corn genome flanking the insert.

PCR analysis confirmed the presence of the FspI fragment in DAS-40278-9. Analysis and comparison with the same region from conventional corn demonstrated that both MARs were adjacent to the genomic DNA. This indicates that no major rearrangements occurred during the creation of DAS-40278-9. However, sequence analysis showed a deletion of 917 bp from the MAR v3 sequence at the 5' insertion site, with a 21 bp insertion and a two bp deletion in the native corn genome. At the 3' insertion site, the MAR v4 element was missing 70bp with a one bp insertion. The sequence of other elements revealed a single bp change in the 3' UTR.

Analysis of the sequences surrounding the insert revealed that insertion of the *aad-1* cassette into the corn genome did not disrupt a known gene. Indeed, the sequences adjacent to the insert (and therefore representing the sequence into which the insert was added) share the greatest similarity to the *Grande* retrotransposons. These retrotransposons are large, *gypsy*-type retrotransposons that replicate via RNA intermediates and are found frequently (approximately 11,000 copies) in the *Z. mays* genome (Garcia-Martinez and Martinez-Izquierdo 2003).

3.4.4 *Open Reading Frame (ORF) analysis of the junction regions*

The nature of the process by which genetic material is introduced into an organism may result in unintended effects that include the creation of new open reading frames (ORFs) in the genome of the organism. These ORFs may, in turn, lead to the production of novel proteins which could have implications for human safety, particularly regarding toxicity and allergenicity, if ingested.

Using the sequence data encompassing the 5' and 3' genomic border sequences (each approximately 1,800 bp in length), the insertion of the *aad-1* cassette into DAS-40278-9 was screened for the presence of ORFs. The study defined an ORF as “any reading frame spanning the junctions regardless of the presence of a start codon and the number of amino acids residues”.

In order to test for similarity to known allergens, any novel ORFs (ORFs covering the junction region) were compared with the FARRP allergen database. Two different tests were done in order to test for similarity to allergens. Firstly, if the ORF was over 80 amino acids in length, comparison was made between each ORF identified and proteins in the database. Sequences were sought which showed more than 35% identity with a known allergen. Secondly, each ORF was used to generate overlapping eight-residue peptides. These peptides were then also compared and identical homologues in known allergens were sought.

Ten novel ORFs were identified in the junction regions of DAS-40278-9. Of these, seven were long enough to search for 35% identity with known allergens. No matches were identified. The overlapping eight-residue peptides of each ORF also failed to elicit matches with known allergens.

To test for similarity of novel ORFs to known toxins, the same ten ORFs were used to search the BLASTp dataset. This dataset contains all known proteins sequences from SWISS-PROT, PIR, PRF, PDB, GenBank and RefSeq. The threshold for similarity was set at $E < 1.0$. This threshold is very low and would return matches of even very limited sequence similarity. Indeed, this threshold is generally set at $E = 1 \times 10^{-5}$ in order to return matches of relevant similarity.

The ten novel ORFs that were identified in the study were subjected to BLASTp analysis. No alignments with an *E*-value less than 1 were returned. These data suggest that in the extremely unlikely event that any of these putative ORFs are expressed, none of the encoded proteins possess similarity to any known allergen or toxin.

3.4.5 *Conclusion about gene characterisation*

The Applicant has provided comprehensive PCR, bioinformatic and Southern blot analyses. These analyses demonstrate that DAS-40278-9 contains a single, complete copy of the *aad-1* expression cassette. It has also been demonstrated that no plasmid backbone is present in corn line DAS-40278-9. Finally, the analyses have shown that no new ORFs were created that show any relevant or significant homology with known allergens or toxins.

3.5 **Stability of genetic changes**

3.5.1 *Generational stability*

In order to determine if the *aad-1* insert is stably inherited, genomic DNA was isolated from several individual plants from generations T3, T4, BC3S1, BC3SS2 and BC3S3 (see Figure 4). This genomic DNA was digested with restriction enzymes and subjected to electrophoresis and Southern hybridisation. The same bands appear for each line/generation, suggesting that the insert in DAS-40278-9 is stably inherited across multiple generations and is not subject to frequent recombination.

3.5.2 *Segregation analysis*

In order to test if the *aad-1* locus segregates according to Mendelian principles, a segregation analysis was undertaken. Plants from the BC3S1 (Back-Cross 3, Self 1)

generation were tested for AAD-1 protein expression, as well as for the presence of the *aad-1* cassette.

To test for AAD-1 protein expression, leaf punches were taken from each of 85 plants of the BC3S1 generation. These leaf punches were analysed using an AAD-1-specific rapid test strip kit. Of the 85 plants, 65 were positive for the AAD-1 protein and 20 showed no AAD-1 protein expression.

The same plants were employed for Southern analysis. Genomic DNA from all 85 plants was extracted, digested with *Nco*I and electrophoresed. After transfer of the DNA to a membrane, the DNA was hybridised with a probe specific for the *aad-1* gene. *Nco*I cuts at the 5' end of the *aad-1* gene and in the adjacent corn genome. Thus a single band of greater than 2764 bp would be expected in each *aad-1*⁺ plant (see Figure 5). As expected, each of the plants testing positive for AAD-1 protein also tested positive for the *aad-1* cassette.

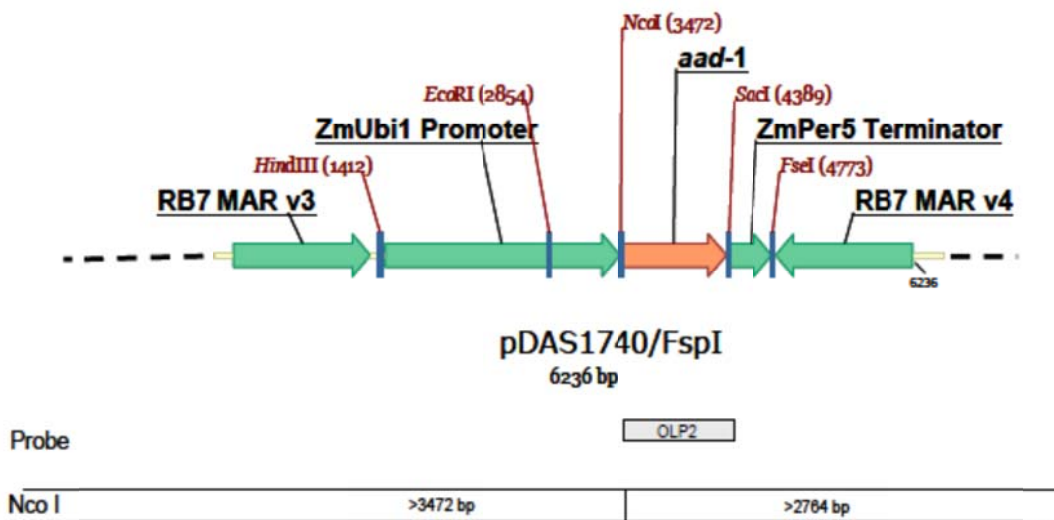

Figure 5: Schematic map of the inserted *aad-1* cassette, the restriction sites within the cassette and the expected fragments resulting from digestion with *Nco*I. The *aad-1*-specific probe, OLP2, hybridises to a single band of greater than 2764 bp.

The segregation ratio of 65 positive plants to 20 negative plants fits the expected single locus segregation ratio of 3:1.

3.5.3 Conclusion about the stability of the genetic change

Taken together, the molecular characterisation of DAS-40278-9 strongly suggests the presence of a single copy of the *aad-1* cassette at a single site. Furthermore, the examination of the insert by Southern hybridisation over several generations and of 65 plants within a single generation strongly suggests that the insert is stably inherited.

3.6 Antibiotic resistance marker genes

No antibiotic marker genes are present in corn DAS-40278-9. Molecular data, including several Southern blots, demonstrate that no plasmid backbone has been integrated into the corn genome during transformation, and the integrated DNA contains no antibiotic resistance gene.

3.7 Conclusion about molecular characterisation

Corn DAS-40278-9 contains one introduced coding sequence with its associated regulatory elements. This sequence contains the *Sphingobium herbicidovorans aad-1* gene. Expression of this gene is intended to provide the plant with tolerance to 2,4-D and AOPP herbicides.

Comprehensive molecular analyses of corn DAS-40278-9 indicate that there is one insertion site at a single locus. This site contains a single copy of the FspI fragment of plasmid pDAS1740. Breeding over five generations has confirmed stability of the introduced genetic elements and segregation data demonstrate their Mendelian inheritance. Backbone analysis shows that no plasmid backbone has been incorporated.

4 CHARACTERISATION OF NOVEL PROTEINS

In considering the safety of novel proteins it is important to consider that a large and diverse range of proteins are ingested as part of the normal human diet without any adverse effects. A small number of proteins have the potential to impair human health, e.g., because they are allergens or anti-nutrients (Delaney et al. 2008). As proteins perform a wide variety of functions, different possible effects have to be considered during the safety assessment including potential toxic, anti-nutritional and allergenic effects. To effectively identify any potential hazards requires knowledge of the characteristics, concentration and localisation of all novel proteins expressed in the organism as well as a detailed understanding of their biochemical function and phenotypic effects. It is also important to determine if the novel protein is expressed as expected, including whether any post-translational modifications have occurred.

4.1 Description and function of the novel protein

The enzymatic specificity of the AAD-1 protein has been characterised (Wright et al. 2010). AAD-1 is able to inactivate the phenoxy herbicide 2,4-D but additionally it has a sufficiently broad substrate spectrum to deactivate other herbicides that act via an entirely different mode of action (i.e. the 'fop' herbicides).

The AAD-1 protein facilitates metabolic detoxification of 2,4-D to 2,4-dichlorophenol (DCP) (refer to Figure 6) by side-chain degradation. Such degradation has been observed in many conventional plants (IPCS 1984) albeit to a limited degree not necessarily associated with tolerance to 2,4-D.

In addition, AAD-1 facilitates degradation of the R-enantiomers of the chiral phenoxy auxins, achiral phenoxy auxins and aryloxyphenoxypropionates (AOPPs) such as quizalofop-P-ethyl to an inactive phenol (refer to Figure 7). In this instance, the first major product in the metabolic pathway is quizalofop-P-acid (refer to Section 5). This general pathway of metabolism is also the same as that occurring in conventional plants that are sprayed with quizalofop-P-ethyl (EPA 1997; EFSA 2008) but, as for the 2,4-D degradation pathway, this is not necessarily linked to herbicide tolerance.

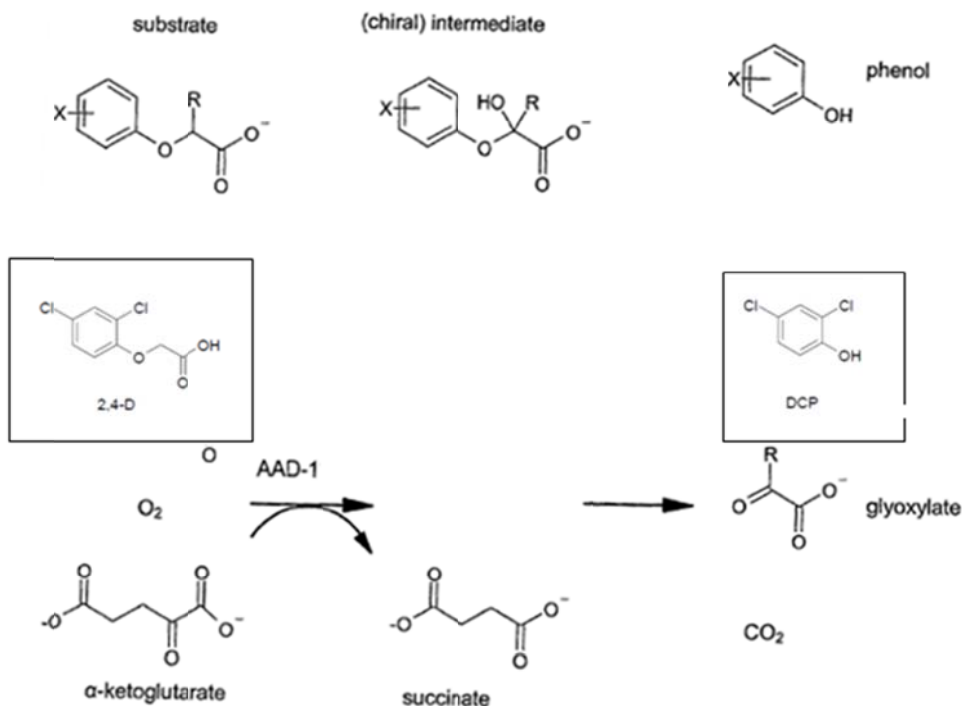

Figure 6: General representation of the conversion of pyridyloxyacetate and phenoxyacetate herbicides to an inactive phenol in the presence of AAD-1 (diagram modified from Wright *et al.* (2009)). The structures of 2,4-D and its inactive phenol, DCP, are given in the boxes.

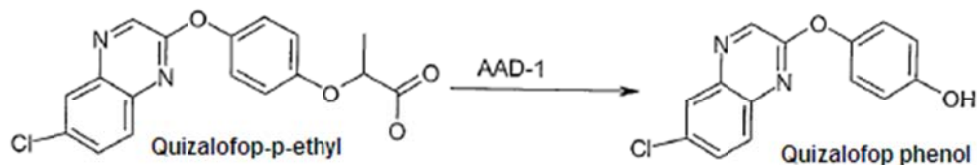

Figure 7: Ultimate metabolism of quizalofop-P-ethyl to quizalofop phenol by AAD-1 (from Wright *et al.* (2009)). Metabolism proceeds primarily by hydrolysis of the ester link to yield quizalofop acid, followed by the loss of the propionyl moiety leading to the quizalofop-phenol metabolite.

4.2 Identification of the AAD-1 protein and equivalence of DAS-40278-9-produced and *P. fluorescens*-produced AAD-1 protein

The amount of AAD-1 protein produced in DAS-40278-9 plants was insufficient for safety evaluations. Therefore, the AAD-1 protein was expressed in *Pseudomonas fluorescens*. In order to establish whether AAD-1 isolated from *P. fluorescens* is equivalent to DAS-40278-9-expressed AAD-1, a range of analytical techniques was employed. These techniques include analysis of molecular weight, protein purity, protein identity (through immunoblot analysis, MALDI-TOF mass spectrometry and N-terminal sequencing), glycosylation analysis and functional activity comparison.

Study submitted:

B.W. Schafer and S.K. Embrey (2009). Characterization of the aryloxyalkanoate dioxygenase-1 (AAD-1) protein derived from transgenic maize event DAS-40278-9. Dow AgroSciences LLC report 080142

The DAS-40278-9-derived AAD-1 protein was purified from lyophilized corn stalk tissue from greenhouse grown F1 hybrid plants using an anti-AAD-1 immunoaffinity column conjugated with a commercially prepared (Strategic Biosolution Inc.) monoclonal antibody. A lateral flow test strip method was used to confirm the expression of the AAD-1 protein in the plants before extraction. Extract from verified (lateral flow test) lyophilized stalks of XHH13 was used as a negative control.

4.2.1 *Molecular weight*

Both SDS-PAGE and Western blotting were used to compare the bacterially-derived protein with immunopurified plant AAD-1 protein and with crude aqueous extracts from lyophilised corn stalk tissue of both DAS-40278-9 and XHH13. Immunoreactivity was detected on the Western blots using a commercially prepared (Strategic Biosolution Inc.) AAD-1 polyclonal rabbit primary antibody and a goat-anti-rabbit alkaline-phosphatase-linked secondary antibody.

The SDS-PAGE analysis of crude plant extracts, as expected, showed a wide range of bands for both DAS-40278-9 and XHH13 and was not informative. The SDS-PAGE gel containing the purified plant and bacterial AAD-1 proteins showed a single band at 33 kDa.

Western blot analysis showed an immunoreactive band at approximately 33 kDa in both lyophilized extract of DAS-40278-9 and bacterially-derived AAD-1. No band was present in the lyophilised extract from XHH13.

In addition to the above, size exclusion liquid chromatography was used to determine that the molecular mass of purified proteins from both microbial- and plant-derived sources was approximately 148 kDa. This suggested that the structure of the protein from both sources was either tetrameric or pentameric, based on a calculated subunit molecular mass of 33.15 kDa. Intact molecular weight analyses were accomplished by ESI-LC/MS¹ and showed for AAD-1 from each source, the presence of one major peak. The observed molecular weights of the protein from each source were within 0.01% of the theoretical molecular weights.

4.2.2 *Amino acid sequence*

ESI-LC/MS analysis following in-solution digestion by trypsin was also used to generate peptide coverage maps of the bacterial- and plant-derived AAD-1. Additionally, the AAD-1 protein from DAS-40278-9 underwent MALDI-TOF² mass spectrometry. The masses of the identified peptides were compared with the expected peptides based on prediction using the Protein Analysis Worksheet (Proteometrics LLC). All peptides were then further analysed using tandem mass spectrometry to give the amino acid residues at the N- and C- termini. These were then compared to the expected amino acid sequences.

For both the LC-MS and MALDI-TOF chromatograms, sequence coverage was approximately 95% for both proteins. The analyses confirmed that the plant-derived protein amino acid sequence matched that of the microbial-derived protein.

Owing to the small amount of protein isolated from the plant source, and, hence the small amount available for analysis, the signal:noise ratio for each amino acid in the tandem MS output for the plant-derived AAD-1 would be anticipated to be low, therefore presenting an element of probability in the spectral interpretation. Analysis of the first 11 residues of the N-terminus of the plant and microbial-derived proteins indicated that, on a probability basis, the

¹ Electrospray ionisation-liquid chromatography/mass spectrometry

² Matrix-assisted laser desorption/ionization-time of flight

sequences were identical and that in both cases, the expected N-terminal methionine was not present. In addition, about 3% of the plant-derived protein showed acetylation of the first alanine residue. Acetylation of the N-termini of proteins, particularly when the N-terminal amino acid is a serine or alanine, is very common, particularly in eukaryotic proteins (Jornvall 1975; Persson et al. 1985)³.

Results for the C-terminal analysis indicated that the last 10 amino acids from both the plant- and microbial-derived AAD-1 were identical and unaltered and were also identical to the expected sequence.

4.2.3 Glycosylation analysis

Glycosylation of a protein is a post-translational modification. Glycoproteins consist of carbohydrate moieties (glycans) covalently linked to a polypeptide backbone. The carbohydrate component may represent <1% to >80% of the total weight. There is evidence that in transgenic plants, expression of non-native proteins may lead to inauthentic glycosylation and concomitant alteration of immunogenicity (see, for example Prescott *et al* (2005)). Characterisation of protein glycosylation in genetically modified plants may therefore assist in informing the risk assessment process.

To assess whether post-translational glycosylation of the DAS-40278-9-derived AAD-1 protein occurred, glycosylation analysis of the purified protein was undertaken. Purified AAD-1 from corn stalk and *P. fluorescens*, as well as horseradish peroxidase (positive control), soybean trypsin inhibitor and bovine serum albumin (both negative controls) were run in duplicate on an SDS-PAGE gel. After electrophoresis, the gel was cut in half. One half was stained for total protein content with GelCode Blue. The remaining half was stained using a periodic acid-Schiff method that specifically detects glycosylated proteins having sialic acid and other oxidizable carbohydrate groups. The controls reacted as expected, but despite clear evidence of the presence of the AAD-1 protein (from the protein stain), there was no evidence of glycosylation. This result, along with the results of the tryptic mass map analysis, demonstrates that there is no difference in glycosylation pattern between the plant-derived and microbe-derived AAD-1 protein, and that neither protein is glycosylated.

4.2.4 Conclusion

A range of characterisation methods confirmed the identity of AAD-1 protein produced both in *P. fluorescens* and in corn DAS-40278-9. Protein from both sources was found to migrate at identical molecular weights, to be recognised by anti-AAD-1 antibodies and to lack glycosylation. Sequencing analysis confirmed that the plant-derived protein amino acid sequence matched that of the microbial-derived protein. Thus the AAD-1 proteins from DAS-40278-9 and *P. fluorescens* can be said to be equivalent. Thus the *P. fluorescens*-derived AAD-1 protein was used as a surrogate for plant-derived AAD-1 in subsequent studies for the safety assessment (i.e. *in vitro* digestion studies, acute toxicity studies).

³ Reviewed in Polevoda and Sherman (2002; 2003)

4.3 AAD-1 protein expression analysis

Study submitted:

A.M. Phillips, R.A. Herman, A.D. Thomas and M. Sosa (2009). Field expression, nutrient composition analysis and agronomic characteristics of a hybrid maize line containing aryloxyalkanoate dioxygenase-1 (AAD-1) – event DAS-40278-9. Dow AgroSciences study 090084

The AAD-1 protein levels in different plant tissues were determined by a validated enzyme linked immunosorbent assay (ELISA) using an AAD-1-specific antibody. Leaf, pollen, root, forage and grain were analysed at different stages (see Table 3).

Table 3: Tissues collected for AAD-1 expression level analysis

Tissue	Approximate growth stage
Leaf	V2-4
Leaf	V9
Pollen	R1
Root	R1
Leaf	R1
Forage	R4
Whole Plant	R6
Grain	R6-maturity

Tissues were collected from six separate field sites⁴ in North America. Four replicate plots of each treatment were planted at each site using a randomised complete block (RCB) design, with a unique randomisation at each site. AAD-1 protein levels in each tissue type were determined by ELISA.

The results (see Table 4) indicate that all parts of DAS-40278-9 corn expressed the AAD-1 protein. Pollen contained the highest concentration of AAD-1 protein, followed by V2-V4 leaf stages. The grain would be the most likely part of the corn plant to be used as food either directly or derived from grain by-products. The average content of AAD-1 protein in mature grain of DAS-40278-9 grain was 4.81 ng/mg dry weight (range 1.07-9.10).

Table 4: Summary of mean concentration levels of AAD-1 protein measured in AAD-1 unsprayed, AAD-1 + Quizalofop-P-ethyl, AAD-1 + 2,4-D and AAD-1 + Quizalofop-P-ethyl and 2,4-D in corn tissues

Corn tissue	Treatment	AAD-1 ng/mg tissue dry weight		
		Mean	Std deviation	Range
V2-V4 Leaf	AAD-1 Unsprayed	13.4	8.00	1.98-29.9
	AAD-1 + Quizalofop-P-ethyl	13.3	6.89	4.75-24.5
	AAD-1 + 2,4-D	14.2	7.16	4.98-26.7
	AAD-1 + Quizalofop-P-ethyl + 2,4-D	12.3	7.09	4.07-22.5
V9 Leaf	AAD-1 Unsprayed	5.96	2.50	2.67-10.9
	AAD-1 + Quizalofop-P-ethyl	5.38	1.84	2.52-9.15
	AAD-1 + 2,4-D	6.37	2.41	3.03-10.9
	AAD-1 + Quizalofop-P-ethyl + 2,4-D	6.52	2.38	3.11-11.1

⁴ Richland, IA; Carlyle, IL; Wyoming, IL; Rockville, IN; York, NE; Branchton, Ontario, Canada

Corn tissue	Treatment	AAD-1 ng/mg tissue dry weight		
		Mean	Std deviation	Range
R1 Leaf	AAD-1 Unsprayed	5.57	1.66	3.47-9.34
	AAD-1 + Quizalofop-P-ethyl	5.70	1.63	2.70-7.78
	AAD-1 + 2,4-D	5.99	1.90	2.40-9.42
	AAD-1 + Quizalofop-P-ethyl + 2,4-D	6.06	2.27	1.55-10.2
Pollen	AAD-1 Unsprayed	127	36.2	56.3-210
	AAD-1 + Quizalofop-P-ethyl	108	29.9	52.2-146
	AAD-1 + 2,4-D	113	30.2	37.5-137
	AAD-1 + Quizalofop-P-ethyl + 2,4-D	112	32.6	45.4-162
R1 Root	AAD-1 Unsprayed	2.92	1.87	0.42-6.10
	AAD-1 + Quizalofop-P-ethyl	3.09	1.80	0.56-6.06
	AAD-1 + 2,4-D	3.92	2.03	0.91-7.62
	AAD-1 + Quizalofop-P-ethyl + 2,4-D	2.87	1.23	1.09-5.56
R4 Forage	AAD-1 Unsprayed	6.87	2.79	2.37-12.1
	AAD-1 + Quizalofop-P-ethyl	7.16	2.84	3.05-11.6
	AAD-1 + 2,4-D	7.32	2.46	2.36-10.6
	AAD-1 + Quizalofop-P-ethyl + 2,4-D	6.84	2.31	2.25-10.3
Whole plant	AAD-1 Unsprayed	4.53	2.55	0.78-8.88
	AAD-1 + Quizalofop-P-ethyl	4.61	2.22	0.75-8.77
	AAD-1 + 2,4-D	5.16	2.53	0.83-10.2
	AAD-1 + Quizalofop-P-ethyl + 2,4-D	4.55	1.77	1.30-8.21
Grain	AAD-1 Unsprayed	5.00	1.53	2.66-8.36
	AAD-1 + Quizalofop-P-ethyl	4.63	1.51	1.07-6.84
	AAD-1 + 2,4-D	4.98	1.78	2.94-9.10
	AAD-1 + Quizalofop-P-ethyl + 2,4-D	4.61	1.62	1.81-7.49

4.4 Potential toxicity of the AAD-1 protein

While the vast majority of proteins ingested as part of the diet are not typically associated with toxic effects, a small number may be harmful to health. Therefore, if a GM food differs from its conventional counterpart by the presence of one or more novel proteins, these proteins should be assessed for their potential toxicity. The main purpose of an assessment of potential toxicity is to establish, using a weight of evidence approach, that the novel protein will behave like any other dietary protein.

The assessment focuses on: whether the novel protein has a prior history of safe human consumption, or is sufficiently similar to proteins that have been safely consumed in food; amino acid sequence similarity with known protein toxins and anti-nutrients; structural properties of the novel protein including whether it is resistant to heat or processing and/or digestion. Appropriate oral toxicity studies in animals may also be considered, particularly where results from the biochemical, bioinformatic, digestibility or stability studies indicate a concern.

4.4.1 History of human consumption

Sphingobium herbicidovorans, as discussed in section 2.1, is a common soil bacterium. It is frequently found in soils where 2,4-D has been applied as a herbicide (Horvath et al. 1990) and as such, is probably to be found on crops inhabited by other Sphingomonads such as

on rice (Videira et al., 2010), corn (Rijavec et al., 2007), papaya (Thomas et al., 2007) and tomato (Enya et al., 2007). It has never been isolated in a clinical setting, and as such, is unlikely to be a human pathogen.

4.4.2 Structural similarity of AAD-1 to known toxins

Study submitted:

I.M. Larrinua and R.A. Herman (2007). AAD-1 amino acid homology search for similarity to toxins. Dow AgroSciences study 071022

Bioinformatic analyses are useful for assessing whether introduced proteins share any amino acid sequence similarity with known protein toxins. The AAD-1 sequence was compared with sequences included in the GenBank non-redundant protein dataset.

For similarity searching, the BLASTP 2.2.10 algorithm (Altschul et al. 1990) was employed. The *E*-score was set to 1.0. This parameter (the *E* value (Baxevanis 2005)) represents the probability that a particular alignment is due to chance. Comparisons between highly homologous proteins yield *E*-values approaching zero, indicating the very low probability that such matches would occur by chance. A larger *E*-value indicates a lower degree of similarity.

The cut-off normally employed to reveal “real” or significant homology is 1×10^{-5} . Therefore a cut-off of 1 would reveal even barely homologous proteins. Indeed, 581 proteins were identified. Of these, 580 were alpha ketoglutarate-dependent dioxygenases (of which AAD-1 is a member). The last protein was a hypothetical protein with no functional annotation, but which shared significant homology to a heavy myosin from *Cryptosporidium hominis* TU502. Thus, no homology with known toxins was identified.

4.4.3 Acute oral toxicity study

Although not required, since no toxicity concerns were raised in the data considered in Sections 4.4.1, 4.4.2 and 4.5.3, the Applicant supplied an acute oral toxicity study using *P. fluorescens*-derived AAD-1 protein. The AAD-1 protein from *P. fluorescens* was shown in rigorous testing to be equivalent to plant-derived AAD-1 (see Section 4.2).

Study submitted:

C.M. Wiescinski and R.M. Golden (2007). AAD-1: acute oral toxicity study in CRL:CD1(ICR) mice. The Dow Chemical Company study 071128

A maximum test dose of 2000 mg AAD-1/kg bw was administered by gavage to CRL:CD1(ICR) mice (5/sex). The dose was administered as a 2 x 12.5 ml/kg bw suspension of 20% test material in 0.5% aqueous methylcellulose approximately one hour apart.

The animals were observed for signs of toxicity daily for 14 days after dosing. Body weights were obtained on test days 1, 2, 8 and 15. At the end of the study, the animals were killed and examined for gross necroscopy findings.

All mice survived the duration of the study. No clinical signs were observed. All animals gained weight during the study. Necroscopy on day 15 revealed no visible lesions in 4/5 male mice and 4/5 female mice. One male mouse had signs of an ulcer in the stomach, and one female mouse had a dark area in the cerebrum of the brain. These gross pathology observations were considered to be incidental and unrelated to treatment. Spontaneous stomach ulceration is reasonably common in *ad libitum* fed mice with an incidence in the range of 5-9% (Rehm et al. 1987). Since the *in vitro* studies convincingly showed that the

AAD-1 protein is enzymatically transformed to very short-chain peptides and/or amino acids under simulated gastric digestion conditions (Section 4.5.3) it is biologically implausible that degraded AAD-1 protein could be absorbed from the GI tract and cross blood-brain barrier to cause pathological lesions in the mouse cerebrum.

Under the conditions of this study, administration of AAD-1 protein to female and male mice at a dose of 2,000 mg /kg bw produced no test substance-related clinical signs of toxicity, body weight losses, macroscopic abnormalities or mortality. These results support the conclusion that the AAD-1 protein is not acutely toxic.

4.5 Potential allergenicity of the AAD-1 protein

The potential allergenicity of novel proteins was evaluated using an integrated, step-wise, case-by-case approach relying on various criteria used in combination. This is because no single criterion is sufficiently predictive of either allergenicity or non-allergenicity (see eg Thomas et al. 2009). The assessment focuses on:

- the source of the novel protein;
- any significant amino acid sequence similarity between the novel protein and known allergens;
- the structural properties of the novel protein, including susceptibility to digestion, heat stability and/or enzymatic treatment; and
- specific serum screening if the novel protein is derived from a source known to be allergenic or has amino acid sequence similarity to a known allergen, additional *in vitro* and *in vivo* immunological testing may be warranted.

Applying this approach systematically provides reasonable evidence about the potential of the novel protein to act as an allergen.

The allergenic potential of the AAD-1 protein was assessed by:

- consideration of the *aad-1* gene source and history of use or exposure
- bioinformatic comparison of the amino acid sequence of the AAD-1 protein with known protein allergen sequences
- evaluation of the stability of the microbially-produced and purified AAD-1 protein from *P. fluorescens* using *in vitro* gastric and intestinal digestion models

4.5.1 Source of protein

The AAD-1 protein is derived from the common soil bacterium *Sphingobium herbicidovorans*. Despite the presence of Sphingomonads in several common food crops (see sections 2.1 and 4.4.1), there have been no reports of either infection by, or allergy to, them.

4.5.2 Similarity to known allergens

Study submitted:

R.A. Herman (2007). AAD-1 amino acid homology search for similarity to allergens. Dow AgroSciences study 071029

Bioinformatic analysis provides part of a “weight of evidence” approach for assessing potential allergenicity of novel proteins introduced to GM plants. It is a method for comparing the amino acid sequence of the introduced protein with sequences of known allergens in order to indicate potential cross-reactivity between allergenic proteins and the introduced

protein. As with the bioinformatic analysis that looked at similarities of the AAD-1 protein with known protein toxins (see section 4.4), the generation of a small *E*-value provides an important indicator of significance of matches (Pearson 2000; Baxevanis, 2005).

To determine whether the AAD-1 protein has significant identity to any proteins known or suspected to be allergens, the amino acid sequence of AAD-1 was compared to a subset of sequences from the Food Allergy Research and Resource Program (FARRP, University of Nebraska) Allergen Database version 7.00. This database contains the amino acid sequences of known and putative allergenic proteins using established criteria (Codex 2003). Potential similarities between the introduced protein in DAS-40278-9 and proteins in the allergen database were evaluated using the FindPatterns and FastA programs. Alignments were sought that contained either eight contiguous amino acid identity or 35% or greater identity over any 80 amino acid segment to known or putative allergens. These two approaches aim to identify both short contiguous regions of identity that could potentially correspond to shared IgE binding epitopes, as well as longer stretches of sequence similarity that may infer a potential cross-reactive protein structure.

None of the proteins in the FARRP database exceeded the 35% threshold over 80 or greater amino acids. Furthermore, there were no eight or greater contiguous identical amino acid stretches in common between the AAD-1 protein sequence and any of the protein sequences in the AAD-1 database. The results indicate that the AAD-1 protein does not show significant sequence identity with known allergens.

4.5.3 *In vitro* digestibility

Typically, food proteins that are allergenic tend to be resistant to enzymes such as pepsin as well as the acidic conditions of the digestive system. This exposes the proteins to the intestinal mucosa and leads to an allergic response (Astwood and Fuchs 1996; Metcalfe et al. 1996; Kimber et al. 1999). Therefore a correlation exists between resistance to digestion by pepsin and potential allergenicity. As a consequence, one of the criteria for assessing potential allergenicity is to examine the stability of novel proteins in conditions mimicking human digestion. Proteins that are rapidly degraded in such conditions are considered less likely to be involved in eliciting a response.

A pepsin digestibility assay was conducted to determine the digestive stability of the AAD-1 protein. The protocol used simulated gastric fluid (SGF) to determine the nature of digestion of the AAD-1 protein in the stomach.

Study submitted:

S.K Embrey & V.A. Korjagin (2008). *In vitro* simulated gastric fluid digestibility of aryloxyalkanoate dioxygenase-1 (abbreviation AAD-1). Dow AgroSciences study 080062

The *in vitro* digestibility of the *P. fluorescens*-derived AAD-1 protein in SGF containing pepsin at pH 1.2 (Thomas et al. 2004) was evaluated by incubating samples at 37°C for selected times (0, 0.5, 1, 2, 4, 8 and 16 minutes) and subjecting these to SDS-PAGE. Proteins were visualised by staining the gel with GelCode Blue. Two control proteins were treated in parallel: bovine serum albumin (BSA) is known to hydrolyse readily in pepsin and served as a positive control; β -lactoglobulin is known to persist in pepsin and was used as a negative control. Western blotting of the SDS gels was also performed using an anti-AAD-1 rabbit polyclonal primary antibody and a goat anti-rabbit horseradish peroxidase-linked secondary antibody.

The SDS-PAGE gels indicated that within 30 seconds of exposure to the SGF, the AAD-1 protein became visually indistinguishable. However, because of co-migration with an SGF-

associated protein, it was not possible to conclude that indeed all the AAD-1 protein had been digested within the 16 minute time frame. The BSA positive control was rapidly hydrolysed (≥ 30 seconds) while the β -lactoglobulin negative control had not been digested after 16 minutes.

From the Western blots it was clear that within 30 seconds, the AAD-1 protein was digested beyond the detection limit of the blot.

These results suggest that the AAD-1 protein is rapidly digested in SGF.

4.6 Conclusion from characterisation of novel protein

Corn DAS-40278-9 expresses one novel protein, AAD-1. The AAD-1 protein was derived from the common soil bacterium, *Sphingobium herbicidovorans*. Members of the Sphingomonads are commonly found in the soil and on food crops and have not been associated with illness or allergy. The AAD-1 protein is expressed at low levels in the grain (4.81ng/mg).

Extensive studies have been done to confirm the identity and physicochemical and functional properties of the expressed AAD-1 protein, as well as to determine its potential toxicity and allergenicity. The protein conforms in size and amino acid sequence to that expected. It does not exhibit any glycosylation.

Bioinformatic studies with the AAD-1 protein have confirmed the absence of any biologically significant amino acid sequence similarity to known protein toxins or allergens and digestibility studies have demonstrated that the protein would be rapidly degraded following ingestion, similar to other dietary proteins. An acute oral toxicity study in mice with the AAD-1 protein has also confirmed the absence of toxicity. Taken together, the evidence indicates that the AAD-1 protein is neither toxic, nor likely to be allergenic, in humans.

5 HERBICIDE METABOLITES

Studies submitted:

Ma, M.; Adelfinskaya, Y.A. (2010). A nature of the residue study with [14 C] 2,4-D DMA applied to AAD-1 corn (event 278)]. Dow AgroSciences study 090058.

Rotondaro, S.L.; Balcer, J.L. (2010). A nature of the residue study with [14 C] 2,4-D DMA applied to AAD-1 corn. Dow AgroSciences study 080058.

Rotondaro, S.L.; Smith, K.P. (2010). A nature of the residue study with [14 C] Quizalofop-P-ethyl ester applied to AAD-1 maize 2008 (event 474). Dow AgroSciences study 050057

Culligan, J.F. (2010). Magnitude of the residue of 2,4-D and Quizalofop-P-ethyl in/on herbicide tolerant field corn containing the aryloxyalkanoate dioxygenase-1 (AAD-1) gene. Dow AgroSciences study 000052

Stagg, N.; Cleveland, C.B.; Blewett, T.C.; Eisenbrandt, D.; Rosser, S.W.; Gollapudi, B.; Carney, E.; Ellis-Hutchings, R. (2010). 2,4-dichlorophenol: Relevance for containing the DAS AAD-1 trait. Dow AgroSciences study 101759.

In order to assess the likely toxicity of any novel herbicide residues in the edible crop it is important to understand what novel herbicide metabolites are likely to be formed through the action of AAD-1. AAD-1 has the ability to selectively cleave members of the aryloxyphenoxypropionate (AOPP) class of herbicides, such as haloxyfop-P, quizalofop-P,

and diclofop-P. The same enzyme also deactivates an entirely different class of herbicide, the phenoxy (auxin) herbicides that includes 2,4-D (refer to Section 4.1). The tolerance of the GM corn to both herbicides means that there is less likelihood of weeds developing resistance than if they were applied separately (Wright et al., 2010).

As a result of the activity of AAD-1 the herbicide residues generated by corn line DAS-40278-9 are identical to those detected in conventional crops (i.e. 2,4- dichlorophenol (DCP) and quizalofop-P acid for 2,4-D and quizalofop-P-ethyl respectively). That is, no herbicide metabolites are produced in DAS-40278-9 that are not also produced in conventional crops treated with these herbicides.

5.1 Residue chemistry studies

Field trials were conducted in 2009 at 25 sites in North America that included two sites in Canada. The trials were located in areas where field corn is commonly grown commercially. Each site had an untreated control plot that was planted with conventional corn and a treated plot that was planted with corn line DAS-40278-9. The treated corn was sprayed with three applications of 2,4-D (Weedar 64) with each application targeted at a rate of 1.12 kg acid equivalents/ha (ae/ha) and one application of quizalofop-P-ethyl (Assure II) targeted at 92 g active ingredient./ha (ai/ha). These rates are equivalent to the maximum seasonal rates for each herbicide. The three applications of 2,4-D were applied at the pre-emergent, approximately V4 or approximately V8 growth stages. The quizalofop-P-ethyl was applied approximately 5 d before the last of the 2,4-D applications. All applications, except for the pre-emergent treatment, were via a boom sprayer.

The overall median residues in corn grain harvested at commercial maturity are summarised in Table 5. The Applicant also supplied data for forage and stover⁵ residues but these have not been included since the focus of this assessment is necessarily on the food uses of corn.

Table 5: Residue levels in grain of corn line DAS-40278-9 sprayed with 2,4-D and quizalofop-P-ethyl (data from Culligan (2010) – see Studies submitted)

Residue	PHI ¹	n	Minimum ²	Maximum	Median (STMR)	Mean
2,4-D	73 - 139	48	ND	(0.004) ³	ND	ND
DCP	73 - 139	48	ND	(0.003)	ND	ND
Quizalofop-P-ethyl	79 - 144	50	ND	(0.004)	ND	ND
Quizalofop-P-acid	79 - 144	50	ND	(0.004)	ND	ND

¹PHI = Pre-harvest interval; days between last application of herbicide and collection of field sample

²ND = not detected (less than the limit of detection of 0.003 µg/g)

³Values in parentheses are greater than or equal to the limit of detection but less than the limit of quantitation (0.01 µg/g)

Based on the proposed use of 2,4-D and quizalofop-P-ethyl in corn line DAS-40278-9, the residue levels of 2,4-D, quizalofop-P-ethyl and their respective metabolites, are all less than the limit of quantitation. Given the time interval between the final application of the two herbicides and harvest, the absence of any quantifiable residues on corn line DAS-40278-9 expressing AAD-1 would not be unexpected.

5.2 ADI for 2,4-D and quizalofop-P-ethyl

⁵ the dried stalks and leaves of a field crop used as animal fodder after the grain has been harvested

As no novel herbicide metabolites are present in treated corn line DAS-40278-9, the existing health-based guidance values (i.e. Acceptable Daily Intake - ADI) for 2,4-D and quizalofop-P-ethyl are appropriate and relevant for assessing dietary risk with corn line DAS-40278-9. In Australia the ADI for 2,4-D is 0.01 mg/kg bw/day⁶. However, there is no specific ADI for quizalofop-P-ethyl but separate ADIs at 0.01 mg/kg bw/day exist for quizalofop-ethyl and quizalofop-P-tefuryl. Quizalofop-ethyl is a racemic mixture of (R,S)-isomers whereas quizalofop-P-tefuryl is an ester of the resolved (R)-isomer quizalofop-P. Hence, the ADI established for quizalofop-P-tefuryl would also be applicable to other esters of quizalofop-P, such as quizalofop-P-ethyl. If a dietary risk assessment is required then these ADIs could be used.

5.3 Conclusion

The major residues generated on corn line DAS-40278-9 as a result of spraying with 2,4-D and quizalofop-P-ethyl are dichlorophenol and quizalofop-P acid. These residues are the same as those found on conventional crops. Residue data derived from supervised trials indicate that the residue levels for both herbicides are below the limit of quantitation. In the absence of any measurable exposure to either parent herbicide or their metabolites the risk to public health and safety is likely to be negligible.

6 COMPOSITIONAL ANALYSES

The main purpose of compositional analysis is to determine if, as a result of the genetic modification, any unexpected changes have occurred to the food. These changes could take the form of alterations in the composition of the plant and its tissues and thus its nutritional adequacy. Compositional analysis can also be important for evaluating the intended effect where there has been a deliberate change to the composition of the food.

The classic approach to the compositional analysis of GM food is a targeted one. Rather than analysing every single constituent, which would be impractical, the aim is to analyse only those constituents most relevant to the safety of the food or that may have an impact on the whole diet. Important analytes therefore include the key nutrients, toxicants and anti-nutrients for the food in question. The key nutrients and anti-nutrients are those components in a particular food that may have a substantial impact in the overall diet. They may be major constituents (fats, proteins, carbohydrates or enzyme inhibitors such as anti-nutrients) or minor constituents (minerals, vitamins). Key toxicants are those toxicologically significant compounds known to be inherently present in an organism, such as compounds whose toxic potency and level may be significant to health (e.g. solanine in potatoes).

6.1 Key components

For corn there are a number of components that are considered to be important for compositional analysis (OECD, 2002; EuropaBio 2003). As a minimum, the key nutrients of corn grain appropriate for a comparative study include the proximates (crude protein, fat, ash, acid detergent fibre and neutral detergent fibre), amino acids and fatty acids. In addition, mineral and vitamin levels may be considered and international guidance also suggests that levels of the key anti-nutrients phytic acid, trypsin inhibitors and raffinose and the secondary metabolites coumaric acid, ferulic acid and furfural should be determined for new varieties of corn. The reasons for focussing on these particular anti-nutrients are:

⁶ADIs are established by the Office of Chemical Safety within the Department of Health and Ageing [http://www.health.gov.au/internet/main/publishing.nsf/Content/E8F4D2F95D616584CA2573D700770C2A/\\$File/ADI-report-may10.pdf](http://www.health.gov.au/internet/main/publishing.nsf/Content/E8F4D2F95D616584CA2573D700770C2A/$File/ADI-report-may10.pdf)

- phytic acid causes chelation of mineral nutrients (including calcium, magnesium, potassium, iron and zinc) thereby making them unavailable to monogastric animals, including humans
- trypsin inhibitors, while not considered nutritionally significant in corn, can interfere with digestion of protein.
- raffinose is a low molecular weight carbohydrate (oligosaccharide) that is associated with production of intestinal gas and resulting flatulence when consumed.
- coumaric and ferulic acids are phenolic acids that might influence digestion.
- furfural is a heterocyclic aldehyde that is considered an oral genotoxic carcinogen of low potency

6.2 Study design and conduct for key components

Study submitted:

A.M. Phillips, R.A. Herman, A.D. Thomas and M. Sosa. (2009). Field expression, nutrient composition analysis and agronomic characteristics of a hybrid maize line containing aryloxyalkanoate dioxygenase-1 (AAD-1) – event DAS-40278-9. Dow AgroSciences study 090084

Ideally, the comparator in compositional analyses should be the near isogenic parental line grown under identical conditions (OECD, 2002). In the case of corn line DAS-40278-9, the control was the hybrid line identified as AxC. This corresponds to a hybrid between “Inbred A” (XHH13) and “Inbred C” (an unidentified DAS elite inbred line). As shown in Figure 4, the original transformation event (T0) was crossed and then backcrossed four times with the Inbred A line, before being self-fertilised once and then crossed with the Inbred C line. The extensive backcrossing of the original event with Inbred A, followed by crossing with Inbred C means that an AxC hybrid is the closest genetic line for the purposes of comparison.

The test and control lines were planted in six field testing facilities in the United States and Canada. At each site, four replicate plots arranged in a randomised complete block design were planted, with a unique randomisation at each site. In order to ascertain if expression and function of the AAD-1 protein in DAS-40278-9 lead to unexpected changes in the composition of the grain, the test line was either left unsprayed, sprayed with quizalofop-P-ethyl alone, sprayed with 2,4-D alone or sprayed with both quizalofop-P-ethyl and 2,4-D.

After harvesting, the corn forage (data not presented in this report) and grain were analysed for nutrient content. The results of the nutritional analysis were compared with values reported in the literature (Watson 1982; Watson 1987; Codex 2001; OECD, 2002; ILSI 2007). Analysis of variance was conducted using a mixed model (SAS Institute Inc 1999), with entry as a fixed effect, and location, block within location, location-by-entry, and entry-by-block within location as random effects. Analysis at individual locations was done in an analogous manner with entry as a fixed effect and block and entry-by-block as random effects. Significant differences were declared at the 95% confidence level.

The significance of an overall treatment effect was estimated using an F-test, while paired contrasts were made between the unsprayed non-GM control and each of the four GM treatments using t-tests. Because paired contrasts were made between all of the various herbicide applications and the control, this was likely to lead to multiplicity. In essence the large number of comparisons was very likely (>99.99%) to lead to falsely declared differences (i.e. the differences may reach significance, but still occurred by chance). In order to adjust for this factor, the applicant applied False Discovery Rate (FDR) procedures (Benjamini and Hochberg 1995). In this way, the P-values from the compositional analyses were adjusted using FDR to enable true differences to be distinguished from random effects. Any statistically significant differences were compared with values in the literature.

6.3 Analyses of key components

Although the applicant provided results for both grain and forage, the focus of this assessment is necessarily on the food uses of corn and therefore the forage data are not presented in this report. In short, no biologically relevant differences were found between DAS-40278-9 and the control in the combined site analysis for forage.

Compositional analyses of the corn grain included proximates (ash, total fat, moisture, protein, carbohydrate and cholesterol), crude fibre, acid detergent fibre (ADF), neutral detergent fibre (NDF), minerals, amino acids, fatty acids, vitamins, secondary metabolites and anti-nutrients.

6.3.1 Proximates and fibre

The results of the proximate and fibre analysis of DAS-40278-9 grain are shown in Table 6. Levels of cholesterol were below the limit of quantitation (LOQ). In the combined site analysis, the mean level of protein was significantly higher in DAS-40278-9 unsprayed, sprayed with quizalofop-P-ethyl and sprayed with both quizalofop-P-ethyl and 2,4-D than in the control. Conversely, the mean level of carbohydrate was significantly lower in these same DAS-40278-9 treatments than in the control. For both protein and carbohydrate, the means for all treatments were well within the literature ranges, suggesting that the significant differences are not biologically meaningful. While there was an overall treatment effect for moisture level, the individual comparisons of the GM treatments with the non-GM control did not show a significant difference, as reflected in the adjusted P-value.

Interestingly, these differences (protein and carbohydrate content) rarely occurred (and only once in more than one herbicide treatment group) at individual sites. Indeed, significant differences in other proximates in more than one herbicide treatment group at individual sites did not occur at all. This suggests that the variation between sites was far greater than the variation within a single site, which is not unexpected.

Table 6: Statistical summary of combined-site corn grain proximate and fibre content

Proximate (% dry weight)	Literature Values	Overall Treatment Effect ¹	Control	Unsprayed (P-value, Adj. P)	Sprayed Quizalofop-P-ethyl (P-value, Adj. P)	Sprayed 2,4-D (P-value, Adj. P)	Sprayed Both (P-value, Adj. P)
Protein	6-17.3	0.003	9.97	10.9 (0.002, 0.016)	11.1 (0.0004, 0.013)	10.5 (0.061, 0.161)	10.9 (0.002, 0.015)
Fat	1.2-18.8	0.369	4.26	4.19 (0.238, 0.397)	4.16 (0.095, 0.215)	4.26 (0.955, 0.977)	4.22 (0.427, 0.615)
Ash	0.62-6.28	0.553	1.45	1.55 (0.178, 0.330)	1.52 (0.364, 0.557)	1.45 (0.982, 0.985)	1.51 (0.397, 0.587)
Moisture	6.1-40.5	0.038	25.1	25.5 (0.406, 0.594)	24.4 (0.056, 0.152)	24.5 (0.117, 0.254)	24.5 (0.114, 0.250)
Cholesterol	NR	NA	<LOQ	<LOQ	<LOQ	<LOQ	<LOQ
Carbohydrate	63.3-89.8	0.005	84.3	83.3 (0.002, 0.015)	83.2 (0.001, 0.013)	83.8 (0.074, 0.185)	83.4 (0.003, 0.019)
Fibre (% dry weight)							
Acid Detergent Fibre (ADF)	1.82-11.3	0.247	4.23	3.94 (0.130, 0.269)	3.99 (0.197, 0.354)	3.89 (0.078, 0.193)	3.82 (0.035, 0.106)

Proximate (% dry weight)	Literature Values	Overall Treatment Effect ¹	Control	Unsprayed (P-value, Adj. P)	Sprayed Quizalofop-P-ethyl (P-value, Adj. P)	Sprayed 2,4-D (P-value, Adj. P)	Sprayed Both (P-value, Adj. P)
Neutral Detergent Fibre (NDF)	5.59-22.6	0.442	10.6	10.3 (0.455, 0.638)	9.89 (0.120, 0.254)	9.90 (0.121, 0.254)	10.3 (0.552, 0.708)
Total Dietary Fibre	8.3-35.3	0.579	13.4	12.8 (0.164, 0.313)	12.9 (0.195, 0.353)	13.1 (0.487, 0.679)	12.9 (0.215, 0.370)

1: Overall treatment effect estimated using an F-test.

Statistically significant differences (adj P) between the control and DAS-40278-9 are highlighted in green.

Statistically significant overall treatment effects are highlighted in grey.

6.3.2 Minerals

The levels of 13 minerals in DAS-40278-9 and near isogenic control were measured. Four minerals (chromium, iodine, selenium and sodium) were below the limit of quantitation. Results of the analysis for minerals are given in Table 7. In the combined site analysis, there were no minerals with an adjusted P-value under 0.05. Thus there were no significant differences between the control and any of the herbicide treatment groups. Similarly, at individual sites, there were no significant differences in adjusted P-values for any herbicide treatments.

Table 7: Statistical summary of combined-site corn grain mineral content

Minerals (mg/100 g dry weight)	Literature Values	Overall Treatment Effect ¹	Control	Unsprayed (P-value, Adj. P)	Sprayed Quizalofop-P-ethyl (P-value, Adj. P)	Sprayed 2,4-D (P-value, Adj. P)	Sprayed Both (P-value, Adj. P)
Calcium	1.27-100	0.493	4.05	4.21 (0.146, 0.289)	4.12 (0.505, 0.687)	4.04 (0.944, 0.977)	4.06 (0.898, 0.957)
Chromium	0.006-0.16	NA	<LOQ	<LOQ	<LOQ	<LOQ	<LOQ
Copper	0.073-1.85	0.963	0.144	0.151 (0.655, 0.782)	0.146 (0.890, 0.957)	0.141 (0.817, 0.911)	0.149 (0.749, 0.863)
Iodine	7.3-81	NA	<LOQ	<LOQ	<LOQ	<LOQ	<LOQ
Iron	0.1-10	0.333	2.49	2.60 (0.086, 0.206)	2.56 (0.310, 0.482)	2.51 (0.801, 0.911)	2.59 (0.145, 0.289)
Magnesium	59.4-1000	0.072	122	0.551 (0.025, 0.082)	128 (0.017, 0.066)	126 (0.145, 0.289)	127 (0.070, 0.177)
Manganese	0.07-5.4	0.099	0.525	129 (0.010, 0.051)	0.524 (0.884, 0.957)	0.526 (0.942, 0.977)	0.532 (0.505, 0.687)
Molybdenum	NR	0.143	261	229 (0.020, 0.072)	236 (0.067, 0.173)	244 (0.206, 0.362)	234 (0.046, 0.132)
Phosphorus	147-750	0.102	289	303 (0.012, 0.057)	300 (0.035, 0.106)	299 (0.055, 0.150)	298 (0.085, 0.206)
Potassium	181-720	0.453	362	368 (0.330, 0.510)	359 (0.655, 0.782)	364 (0.722, 0.839)	357 (0.454, 0.638)

Minerals (mg/100 g dry weight)	Literature Values	Overall Treatment Effect ¹	Control	Unsprayed (P-value, Adj. P)	Sprayed Quizalofop-P-ethyl (P-value, Adj. P)	Sprayed 2,4-D (P-value, Adj. P)	Sprayed Both (P-value, Adj. P)
Selenium	0.001-0.1	NA	<LOQ	<LOQ	<LOQ	<LOQ	<LOQ
Sodium	0-150	NA	<LOQ	<LOQ	<LOQ	<LOQ	<LOQ
Zinc	0.65-3.72	0.166	2.26	2.32 (0.183, 0.336)	2.34 (0.108, 0.238)	2.29 (0.627, 0.768)	2.37 (0.027, 0.085)

1: Overall treatment effect estimated using an F-test.

Statistically significant differences (adj P) between the control and DAS-40278-9 are highlighted in green.

Statistically significant overall treatment effects are highlighted in grey.

6.3.3 Amino Acids

Levels of 18 amino acids were measured in grain from DAS-40278-9 corn and the conventional control. In the combined site analysis, all amino acids except arginine, glycine, lysine, tryptophan and tyrosine showed significant differences (in the adjusted P-value) from the control. The levels of amino acids found in DAS-40278-9 grain were universally higher than the control (see Table 8), which is not surprising given the significantly higher levels of protein in DAS-40278-9 grain (combined site analysis only). Despite the high number of significant differences in the combined-site analysis, analysis of individual sites failed to show a single significant difference (adjusted P-values). This concurs with the proximate analysis, and demonstrates the much greater inter-site differences than intra-site differences. All differences found were within the values available in the literature, and thus do not represent biologically relevant differences.

Table 8: Statistical summary of combined-site corn grain amino acid content

Amino acid (% dry weight)	Literature Values	Overall Treatment Effect ¹	Control	Unsprayed (P-value, Adj. P)	Sprayed Quizalofop-P-ethyl (P-value, Adj. P)	Sprayed 2,4-D (P-value, Adj. P)	Sprayed Both (P-value, Adj. P)
Alanine	0.44-1.39	0.002	0.806	0.901 (0.0005, 0.013)	0.900 (0.0005, 0.013)	0.863 (0.021, 0.074)	0.894 (0.001, 0.013)
Arginine	0.12-0.64	0.371	0.486	0.499 (0.286, 0.450)	0.505 (0.139, 0.283)	0.487 (0.929, 0.970)	0.484 (0.897, 0.957)
Aspartic acid	0.34-1.21	0.010	0.712	0.768 (0.002, 0.015)	0.764 (0.003, 0.021)	0.743 (0.060, 0.160)	0.762 (0.004, 0.027)
Cysteine	0.08-0.51	0.033	0.213	0.225 (0.009-0.050)	0.223 (0.020, 0.072)	0.223 (0.018, 0.067)	0.226 (0.005, 0.028)
Glutamic acid	0.97-3.54	0.001	1.97	2.22 (0.0003, 0.013)	2.21 (0.0004, 0.013)	2.12 (0.017, 0.067)	2.20 (0.001, 0.013)
Glycine	0.18-0.54	0.052	0.383	0.397 (0.018, 0.067)	0.398 (0.013, 0.059)	0.390 (0.217, 0.371)	0.397 (0.016, 0.066)
Histidine	0.14-0.43	0.005	0.283	0.303 (0.001, 0.013)	0.302 (0.002, 0.014)	0.295 (0.036, 0.109)	0.302 (0.002, 0.014)
Isoleucine	0.018-0.71	0.003	0.386	0.427 (0.001, 0.014)	0.427 (0.001, 0.014)	0.410 (0.044, 0.127)	0.431 (0.001, 0.013)

Amino acid (% dry weight)	Literature Values	Overall Treatment Effect ¹	Control	Unsprayed (P-value, Adj. P)	Sprayed Quisqualofop-P-ethyl (P-value, Adj. P)	Sprayed 2,4-D (P-value, Adj. P)	Sprayed Both (P-value, Adj. P)
Leucine	0.64-2.49	0.001	1.35	1.54 (0.0003, 0.013)	1.54 (0.0003, 0.013)	1.47 (0.013, 0.059)	1.53 (0.001, 0.013)
Lysine	0.05-0.56	0.211	0.310	0.315 (0.210, 0.367)	0.316 (0.128, 0.256)	0.309 (0.879, 0.956)	0.316 (0.102, 0.226)
Methionine	0.10-0.47	0.003	0.195	0.209 (0.001, 0.013)	0.209 (0.001, 0.013)	0.205 (0.014, 0.061)	0.208 (0.001, 0.014)
Phenylalanine	0.24-0.93	0.002	0.551	0.617 (0.001, 0.013)	0.619 (0.001, 0.013)	0.592 (0.023, 0.077)	0.615 (0.001, 0.013)
Proline	0.46-1.63	0.002	0.910	1.01 (0.0004, 0.013)	1.01 (0.001, 0.013)	0.975 (0.012, 0.059)	0.997 (0.001, 0.014)
Serine	0.24-0.91	0.009	0.498	0.550 (0.002, 0.014)	0.550 (0.001, 0.014)	0.529 (0.042, 0.122)	0.536 (0.015, 0.061)
Threonine	0.22-0.67	0.005	0.364	0.394 (0.001, 0.014)	0.394 (0.001, 0.013)	0.384 (0.023, 0.077)	0.390 (0.003, 0.020)
Tryptophan	0.03-0.22	0.088	0.052	0.055 (0.067, 0.173)	0.056 (0.025, 0.082)	0.056 (0.014, 0.060)	0.056 (0.029, 0.092)
Tyrosine	0.10-0.79	0.390	0.336	0.355 (0.535, 0.708)	0.375 (0.214, 0.370)	0.339 (0.907, 0.964)	0.314 (0.500, 0.687)
Valine	0.21-0.86	0.005	0.495	0.537 (0.002, 0.014)	0.538 (0.002, 0.014)	0.519 (0.054, 0.148)	0.538 (0.001, 0.014)

1: Overall treatment effect estimated using an F-test.

Statistically significant differences (adj P) between the control and DAS-40278-9 are highlighted in **green**.

Statistically significant overall treatment effects are highlighted in **grey**.

6.3.4 Fatty Acids

The levels of 22 fatty acids in DAS-40278-9 and the conventional control were measured. The majority (14) of the fatty acids tested were below limit of quantitation. The combined site analysis shows that none of the fatty acids tested was significantly different from those in the conventional control (adjusted P-values) (see Table 9). While there was an overall treatment effect for the level of behenic acid, the individual comparisons of the GM treatments with the non-GM control did not show a significant difference, as reflected in the adjusted P-value.

Table 9: Statistical summary of combined-site corn grain fatty acid content

Fatty acids (% total fatty acids)	Literature Values	Overall Treatment Effect ¹	Control	Unsprayed (P-value, Adj. P)	Sprayed Quisqualofop-P-ethyl (P-value, Adj. P)	Sprayed 2,4-D (P-value, Adj. P)	Sprayed Both (P-value, Adj. P)
8:0 Caprylic	0.13-0.34	NA	<LOQ	<LOQ	<LOQ	<LOQ	<LOQ
10:0 Capric	ND	NA	<LOQ	<LOQ	<LOQ	<LOQ	<LOQ

Fatty acids (% total fatty acids)	Literature Values	Overall Treatment Effect ¹	Control	Unsprayed (P-value, Adj. P)	Sprayed Quizalofop-P-ethyl (P-value, Adj. P)	Sprayed 2,4-D (P-value, Adj. P)	Sprayed Both (P-value, Adj. P)
12:0 Lauric	ND-0.687	NA	<LOQ	<LOQ	<LOQ	<LOQ	<LOQ
14:0 Myristic	ND-0.3	NA	<LOQ	<LOQ	<LOQ	<LOQ	<LOQ
14:1 Myristoleic	NR	NA	<LOQ	<LOQ	<LOQ	<LOQ	<LOQ
15:0 Pentadecanoic	NR	NA	<LOQ	<LOQ	<LOQ	<LOQ	<LOQ
15:1 Pentadecenoic	NR	NA	<LOQ	<LOQ	<LOQ	<LOQ	<LOQ
16:0 Palmitic	7-20.7	0.559	9.83	9.89 (0.618, 0.763)	9.95 (0.280, 0.445)	9.78 (0.617, 0.763)	9.90 (0.544, 0.708)
16:1 Palmitoleic	ND-1.0	NA	<LOQ	<LOQ	<LOQ	<LOQ	<LOQ
17:0 Heptadecanoic	ND-0.11	NA	<LOQ	<LOQ	<LOQ	<LOQ	<LOQ
17:1 Heptadecenoic	ND-0.1	NA	<LOQ	<LOQ	<LOQ	<LOQ	<LOQ
18:0 Stearic	ND-3.4	0.561	2.04	1.98 (0.119, 0.254)	2.01 (0.437, 0.626)	2.00 (0.259, 0.421)	2.02 (0.598, 0.756)
18:1 Oleic	17.4-46	0.076	31.3	30.4 (0.013, 0.059)	30.8 (0.178, 0.329)	30.4 (0.015, 0.061)	30.7 (0.092, 0.213)
18:2 Linoleic	34.0-70	0.474	47.5	48.3 (0.189, 0.345)	48.4 (0.144, 0.289)	48.0 (0.453, 0.638)	48.5 (0.119, 0.254)
18:3 Gamma linoleic	NR	NA	<LOQ	<LOQ	<LOQ	<LOQ	<LOQ
18:3 Linolenic	ND-2.25	0.479	1.04	1.05 (0.537, 0.708)	1.06 (0.202, 0.357)	1.04 (0.842, 0.932)	1.06 (0.266, 0.428)
20:0 Arachidic	0.1-2	0.379	0.400	0.386 (0.061, 0.161)	0.393 (0.341, 0.525)	0.390 (0.153, 0.297)	0.390 (0.175, 0.328)
20:1 Eicosenoic	0.17-1.92	0.107	0.232	0.226 (0.089, 0.210)	0.230 (0.497, 0.687)	0.223 (0.013, 0.059)	0.227 (0.121, 0.254)
20:2 Eicosadienoic	ND-0.53	NA	<LOQ	<LOQ	<LOQ	<LOQ	<LOQ
20:3 Eicosatrienoic	0.275	NA	<LOQ	<LOQ	<LOQ	<LOQ	<LOQ
20:4 Arachidonic	0.465	NA	<LOQ	<LOQ	<LOQ	<LOQ	<LOQ
22:0 Behenic	ND-0.5	0.044	0.136	0.088 (0.093, 0.213)	0.076 (0.887, 0.957)	0.086 (0.011, 0.054)	0.108 (0.023, 0.077)

1: Overall treatment effect estimated using an F-test.

Statistically significant differences (adj P) between the control and DAS-40278-9 are highlighted in green.

Statistically significant overall treatment effects are highlighted in grey.

6.3.5 Vitamins

Vitamin analysis was done for 11 vitamins. In the combined-site analysis, significant differences (adjusted P-values) were seen in vitamin C and niacin (see Table 10). where means for two of the DAS-40278-9 sprayed treatments were significantly lower than the mean for the control. Niacin levels were within levels reported in the literature, and the differences were not consistent across treatments. Vitamin C levels could not be compared with historical results, as no data were available on vitamin C levels in corn. However, the differences seen were not consistent across treatments and quite small (~14%). Individual site analysis revealed no significant differences between the conventional control and DAS-40278-9 for any of the other vitamins.

Table 10: Statistical summary of combined-site corn grain vitamin content

Vitamins (mg/kg dry weight)	Literature Values	Overall Treatment Effect ¹	Control	Unsprayed (P-value, Adj. P)	Sprayed Quizalofop-P-ethyl (P-value, Adj. P)	Sprayed 2,4-D (P-value, Adj. P)	Sprayed Both (P-value, Adj. P)
Beta carotene (vitamin A)	0.19-46.8	0.649	1.80	1.85 (0.372, 0.566)	1.80 (0.967, 0.983)	1.82 (0.770, 0.883)	1.87 (0.221, 0.376)
Vitamin B1 (thiamin)	1.3-40	0.068	3.47	3.63 (0.041, 0.121)	3.67 (0.013, 0.059)	3.54 (0.375, 0.567)	3.64 (0.032, 0.100)
Vitamin B2 (riboflavin)	0.25-5.6	0.803	2.15	2.05 (0.443, 0.631)	2.08 (0.600, 0.756)	1.99 (0.227, 0.383)	2.07 (0.543, 0.708)
Vitamin B5 (pantothenic acid)	NR	0.820	5.28	5.17 (0.623, 0.766)	5.09 (0.391, 0.582)	5.29 (0.968, 0.983)	5.10 (0.424, 0.615)
Vitamin B6 (pyridoxine)	3.68-11.3	0.431	6.52	6.57 (0.859, 0.938)	6.66 (0.652, 0.782)	6.66 (0.652, 0.782)	7.08 (0.088, 0.210)
Vitamin B12	NR	NA	<LOQ	<LOQ	<LOQ	<LOQ	<LOQ
Vitamin C	NR	0.018	22.4	21.2 (0.268, 0.429)	17.5 (0.005, 0.028)	18.0 (0.004, 0.026)	20.4 (0.068, 0.173)
Vitamin D	NR	NA	<LOQ	<LOQ	<LOQ	<LOQ	<LOQ
Vitamin E (alpha tocopherol)	1.5-68.7	0.558	<LOQ	<LOQ	<LOQ	<LOQ	<LOQ
Niacin (nicotinic acid, vit. B3)	9.3-70	0.013	26.1	24.2 (0.050, 0.140)	22.9 (0.002, 0.017)	23.7 (0.018, 0.067)	22.9 (0.002, 0.016)
Folic acid	0.15-683	0.881	0.594	0.588 (0.779, 0.890)	0.574 (0.403, 0.592)	0.592 (0.931, 0.970)	0.597, 0.916, 0.970)

1: Overall treatment effect estimated using an F-test.

Statistically significant differences (adj P) between the control and DAS-40278-9 are highlighted in green.

Statistically significant overall treatment effects are highlighted in grey.

6.3.6 Secondary metabolites

Corn grain from DAS-40278-9 and the conventional control were analysed for secondary metabolite content. Four secondary metabolites were measured (Coumaric acid, Ferulic acid, furfural and inositol) (see Table 11). Levels of furfural were below the detectable limit.

There were no significant differences between DAS-40278-9 and the control, either in the single-site or in the combined-site analysis.

Table 11: Statistical summary of combined-site corn grain secondary metabolite content

Secondary metabolite (% dry weight)	Literature Values	Overall Treatment Effect ¹	Control	Unsprayed (P-value, Adj. P)	Sprayed Quizalofop-P-ethyl (P-value, Adj. P)	Sprayed 2,4-D (P-value, Adj. P)	Sprayed Both (P-value, Adj. P)
Coumaric acid	0.003-0.058	0.119	0.021	0.020 (0.038, 0.113)	0.020 (0.090, 0.211)	0.019 (0.022, 0.074)	0.020 (0.029, 0.091)
Ferulic acid	0.02-0.389	0.077	0.208	0.199 (0.051, 0.141)	0.196 (0.010, 0.051)	0.200 (0.080, 0.196)	0.197 (0.019, 0.069)
Furfural	0.0006-0.003	NA	<LOQ	<LOQ	<LOQ	<LOQ	<LOQ
Inositol	0.0089-0.377	0.734	0.218	0.224 (0.548, 0.708)	0.218 (0.973, 0.984)	0.213 (0.612, 0.763)	0.211 (0.526, 0.708)

1: Overall treatment effect estimated using an F-test.

Statistically significant differences (adj P) between the control and DAS-40278-9 are highlighted in green.

Statistically significant overall treatment effects are highlighted in grey.

6.3.7 Anti-nutrients

Levels of three anti-nutrients in grain from DAS-40278-9 and the conventional control were tested. One anti-nutrient, phytic acid, was found to be significantly higher than the control in the unsprayed context only (see Table 12) in the combined-site analysis. However, this difference was not seen in any individual site, and was only seen in one treatment group. Therefore, this difference would appear to have arisen by chance and is not biologically relevant.

Table 12: Statistical summary of combined-site corn grain anti-nutrient content

Anti-nutrient (% dry weight)	Literature Values	Overall Treatment Effect ¹	Control	Unsprayed (P-value, Adj. P)	Sprayed Quizalofop-P-ethyl (P-value, Adj. P)	Sprayed 2,4-D (P-value, Adj. P)	Sprayed Both (P-value, Adj. P)
Phytic acid	0.11-1.57	0.046	0.727	0.806 (0.003, 0.020)	0.767 (0.099, 0.224)	0.755 (0.245, 0.402)	0.761 (0.158, 0.304)
Raffinose	0.02-0.32	NA	<LOQ	<LOQ	<LOQ	<LOQ	<LOQ
Trypsin inhibitor (TIU/mg)	1.09-7.18	0.742	5.08	5.10 (0.954, 0.977)	4.87 (0.631, 0.770)	5.45 (0.387, 0.582)	5.18 (0.813, 0.911)

6.4 Conclusion from compositional studies

Detailed compositional analyses were done to establish the nutritional adequacy of grain from DAS-40278-9 and to characterise any unintended compositional changes. Analyses were done of proximates, fibre, minerals, amino acids, fatty acids, vitamins, secondary metabolites and anti-nutrients. The levels were compared to levels in the non-GM near isogenic line and levels recorded in the literature. Several analytes, especially among the amino acids, deviated from the control in a statistically significant manner. However, analysis

of individual sites failed to reproduce these differences. Furthermore, in no case was any difference in the combined-site analysis consistent across all treatment groups. Lastly, all analytes fell within the historical range from the literature. It can therefore be concluded that grain from DAS-40278-9 is compositionally equivalent to grain from conventional corn varieties.

7 NUTRITIONAL IMPACT

In assessing the safety of a GM food, a key factor is the need to establish that the food is nutritionally adequate and will support typical growth and well being. In most cases, this can be achieved through an understanding of the genetic modification and its consequences, together with an extensive compositional analysis of the food.

Where a GM food has been shown to be compositionally equivalent to conventional varieties, the evidence to date indicates that feeding studies using target livestock species will add little to the safety assessment and are generally not warranted (OECD 2003).

If the compositional analysis indicates biologically significant changes to the levels of certain nutrients in the GM food, additional nutritional assessment should be undertaken to assess the consequences of the changes and determine whether nutrient intakes are likely to be altered by the introduction of such foods into the food supply. This assessment should include consideration of the bioavailability of the modified nutrient.

In this case, DAS-40278-9 corn is the result of a simple genetic modification to confer tolerance to herbicides. There was no intention to significantly alter nutritional parameters in the food. In addition, extensive compositional analyses have been undertaken of DAS-40278-9 and these indicate it is equivalent in composition to conventional corn varieties. The introduction of corn DAS-40278-9 into the food supply would therefore be expected to have little nutritional impact.

REFERENCES⁷

Abranches R, Shultz RW, Thompson WF, Allen GC (2005) Matrix attachment regions and regulated transcription increase and stabilize transgene expression. *Plant Biotechnology Journal* 3(5):535–543

Ainley, M., Armstrong, K., Belmar, S., Folkerts, O., Hopkins, N., Menke, M. A., Paredy, D., Petolino, J. F., Smith, K., Woosley, A. (2002) Regulatory sequences from transgenic plants. Patent US6384207

Alarcon A, Davies JFT, Autenrieth RL, Zuberer DA (2008) Arbuscular mycorrhiza and petroleum-degrading microorganisms enhance phytoremediation of petroleum-contaminated soil. *International Journal of Phytoremediation* 10:251–263

Altschul SF, Gish W, Miller W, Myers EW, Lipman DJ (1990) Basic local alignment search tool. *Journal of Molecular Biology* 215(3):403–410

Astwood JD, Fuchs RL (1996) Allergenicity of foods derived from transgenic plants. *Monographs in Allergy* 32 (Highlights in Food Allergy):105–120

⁷ All websites were current as at 29 June 2011

- Bauer R, Bekker JP, van Wyk N, du Toit C, Dicks LMT, Kossmann J (2009) Exopolysaccharide production by lactose-hydrolyzing bacteria isolated from traditionally fermented milk. *International Journal of Food Microbiology* 131(2-3):260–264
- Baxevanis AD (2005) Assessing Pairwise Sequence Similarity: BLAST and FASTA. Ch 11 In: Baxevanis AD, Ouellette BFF (eds) *Bioinformatics: A Practical Guide to the Analysis of Genes and Proteins*. John Wiley & Sons, Inc., p. 295–324
- Benjamini Y, Hochberg Y (1995) Controlling the false discovery rate: a practical and powerful approach to multiple testing. *Journal of the Royal Statistical Society Series B-Methodological* 57(1):289–300
- CFIA (1994) *The Biology of Zea mays L. (Corn/Maize)*. BIO1994-11. Canadian Food Inspection Agency, Ottawa.
<http://www.inspection.gc.ca/english/plaveg/bio/dir/dir9411e.pdf>
- Christensen AH, Quail PH (1996) Ubiquitin promoter-based vectors for high-level expression of selectable and/or screenable marker genes in monocotyledonous plants. *Transgenic Research* 5(3):213–218
- Christensen AH, Sharrock RA, Quail PH (1992) Maize polyubiquitin genes: structure, thermal perturbation of expression and transcript splicing, and promoter activity following transfer to protoplasts by electroporation. *Plant Molecular Biology* 18(4):675–689
- Codex (2001) *Codex Standard for Named Vegetable Oils*. CX-STAN 210 – 1999. Codex Alimentarius.
http://www.codexalimentarius.net/web/standard_list.do?lang=en
- Codex (2003) *Guideline for the Conduct of Food Safety Assessment of Foods Derived from Recombinant-DNA Plants*. CAC/GL 45-2003. Codex Alimentarius.
http://www.codexalimentarius.net/web/standard_list.do?lang=en
- CRA (2006) *Corn oil*. 5 ed, Corn Refiners Association, Washington D.C.
<http://www.corn.org/wp-content/uploads/2009/12/CornOil.pdf>.
- Delaney B, Astwood JD, Cunny H, Eichen Conn R, Herouet-Guicheney C, MacIntosh S, Meyer LS, Privalle LS, Gao Y, Mattsson J, Levine M, ILSI (2008) Evaluation of protein safety in the context of agricultural biotechnology. *Food and Chemical Toxicology* 46:S71–S97
- EFSA (2008) Conclusion regarding the peer review of the pesticide risk assessment of the active substance quizalofop-P (considered variants quizalofop-P-ethyl and quizalofop-P-tefuryl). 205. European Food Safety Authority.
<http://www.efsa.europa.eu/en/efsajournal/doc/205r.pdf>
- Enya J, Shinohara H, Yoshida S, Tsukiboshi T, Negishi H, Suyama K, Tsushima S (2007) Culturable Leaf-Associated Bacteria on Tomato Plants and Their Potential as Biological Control Agents. *Microbial Ecology* 53(4):524–536
- EPA (1997) *Quizalofop-p-ethyl (Assure, Super) Pesticide Petition Filing 12/97*. Environmental Protection Agency, Federal Register Online.

http://pmep.cce.cornell.edu/profiles/herb-growthreg/naa-rimsulfuron/quizalofop-p-ethyl/quizalofop-ethyl_pet_1297.html

EuropaBio (2003) The European Association for Bioindustries. Safety Assessment of GM Crops, Document 1.1, Substantial Equivalence - Maize. Issue 2.
<http://www.europabio.org/relatedinfo/CP11.pdf>

FAOSTAT (2010) Online database of the Food and Agriculture Organization of the United Nations.
<http://faostat.fao.org/>

Fialho A, Moreira L, Granja A, Popescu A, Hoffmann K, Si-Correia I (2008) Occurrence, production, and applications of gellan: current state and perspectives. *Applied Microbiology and Biotechnology* 79(6):889–900

Garcia-Martinez J, Martinez-Izquierdo JA (2003) Study on the Evolution of the Grande Retrotransposon in the Zea Genus. *Mol Biol Evol* 20(5):831–841

Hall Jr G, Allen GC, Loer DS, Thompson WF, Spiker S (1991) Nuclear scaffolds and scaffold-attachment regions in higher plants. *Proceedings of the National Academy of Sciences* 88(20):9320–9324

Han KH, Ma CAIP, Strauss SH (1997) Matrix attachment regions (MARs) enhance transformation frequency and transgene expression in poplar. *Transgenic Research* 6(6):415–420

Horvath M, Ditzelmuller G, Loidl M, Streichsbier F (1990) Isolation and characterization of a 2-(2,4-dichlorophenoxy) propionic acid-degrading soil bacterium. *Applied Microbiology and Biotechnology* 33(2):213–216

ILSI (2007) International Life Sciences Institute Crop Composition Database Version 3.0.
http://www.cropcomposition.org/cgi-perl/search_ora.cgi

IPCS (1984) 2,4-Dichlorophenoxyacetic acid (2,4-D). Environmental Health Criteria 29. International Programme on Chemical Safety INCHEM.
<http://www.inchem.org/documents/ehc/ehc/ehc29.htm>

Jornvall H (1975) Acetylation of protein N-terminal amino groups structural observations on [alpha]-amino acetylated proteins. *Journal of Theoretical Biology* 55(1):1–12

Kimber I, Kerkvliet NI, Taylor SL, Astwood JD, Sarlo K, Dearman RJ (1999) Toxicology of protein allergenicity: prediction and characterization. *Toxicological Sciences* 48(2):157–162

Metcalfe DD, Astwood JD, Townsend R, Sampson HA, Taylor SL, Fuchs RL (1996) Assessment of the allergenic potential of foods derived from genetically engineered crop plants. *Critical Reviews in Food Science and Nutrition* 36 Suppl:S165–S186

OECD (2002) Consensus document on compositional considerations for new varieties of maize (*Zea mays*): Key food and feed nutrients, antinutrients and secondary plant metabolites. Organisation for Economic Co-operation and Development, Paris.
[http://www.oecd.org/officialdocuments/displaydocumentpdf?cote=env/jm/mono\(2002\)25&doclanguage=en](http://www.oecd.org/officialdocuments/displaydocumentpdf?cote=env/jm/mono(2002)25&doclanguage=en)

OECD (2003) Considerations for the safety assessment of animal feedstuffs derived from genetically modified plants. ENV/JM/MONO(2003)10. Organisation for Economic Co-operation and Development, Paris.
<http://www.oecd.org/dataoecd/16/40/46815216.pdf>

OGTR (2008) The biology of *Zea mays* L. ssp *mays* (maize or corn). Prepared by the Office of the Gene Technology Regulator, Australia.
[http://www.ogtr.gov.au/internet/ogtr/publishing.nsf/Content/maize-3/\\$FILE/biologymaize08_2.pdf](http://www.ogtr.gov.au/internet/ogtr/publishing.nsf/Content/maize-3/$FILE/biologymaize08_2.pdf)

Pearson WR (2000) Flexible Sequence Similarity Searching with the FASTA3 Program Package. Ch 10 In: Misener S, Krawetz SA (eds) Methods in Molecular Biology, Volume 132: Bioinformatics Methods and Protocols. Human Press Inc., Totowa, NJ, p. 185–219

Persson B, Flinta C, von Heijne G, Jornvall H (1985) Structures of N-terminally acetylated proteins. European Journal of Biochemistry 152(3):523–527

Polevoda B, Sherman F (2002) The diversity of acetylated proteins. Genome Biology 3(5):1–6

Polevoda B, Sherman F (2003) N-terminal Acetyltransferases and Sequence Requirements for N-terminal Acetylation of Eukaryotic Proteins. Journal of Molecular Biology 325(4):595–622

Pozo C, Rodelas B, Martinez-Toledo MV, Vilchez R, Gonzalez-Lopez J (2007) Removal of organic load from olive washing water (OWW) by an aerated submerged biofilter and profiling of the bacterial community involved in the process. Journal of Microbiology and Biotechnology 17(5):784–791

Prescott VA, Campbell PM, Moore A, Mattes J, Rothenberg ME, Foster PS, Higgins TJV, Hogan SP (2005) Transgenic expression of bean α -amylase inhibitor in peas results in altered structure and immunogenicity. Journal of Agricultural and Food Chemistry 53:9023–9030

Rehm S, Sommer R, Deerberg F (1987) Spontaneous nonneoplastic gastric lesions in female Han:NMRI mice, and influence of food restriction throughout life. Veterinary Pathology 24(3):216–225

Rijavec T, Lapanje A, Dermastia M, Rupnik M (2007) Isolation of bacterial endophytes from germinated maize kernels. Canadian Journal of Microbiology 53(6):802–808

SAS Institute Inc (1999) SAS/STAT user's guide, version 8., SAS Institute Inc, Cary NC

- Takeuchi M, Hamana K, Hiraishi A (2001) Proposal of the genus *Sphingomonas* sensu stricto and three new genera, *Sphingobium*, *Novosphingobium* and *Sphingopyxis*, on the basis of phylogenetic and chemotaxonomic analyses. *International Journal of Systematic and Evolutionary Microbiology* 51(4):1405–1417
- Thomas K, MacIntosh S, Bannon G, Herouet-Guicheney C, Holsapple M, Ladics G, McClain S, Vieths S, Woolhiser M, Privalle L (2009) Scientific advancement of novel protein allergenicity evaluation: An overview of work from the HESI Protein Allergenicity Technical Committee (2000 - 2008). *Food and Chemical Toxicology* 47:1041–1050
- Thomas K, Aalbers M, Bannon GA, Bartels M, Dearman RJ, Esdaile DJ, Fu TJ, Glatt CM, Hadfield N, Hatzos C, Hefle SL, Heylings JR, Goodman RE, Henry B, Herouet C, Holsapple M, Ladics GS, Landry TD, MacIntosh SC, Rice EA, Privalle LS, Steiner HY, Teshima R, Van Ree R, Woolhiser M, Zawodny J (2004) A multi-laboratory evaluation of a common *in vitro* pepsin digestion assay protocol used in assessing the safety of novel proteins. *Regulatory Toxicology and Pharmacology* 39:87–98
- Thomas P, Kumari S, Swarna GK, Gowda TKS (2007) Papaya shoot tip associated endophytic bacteria isolated from *in vitro* cultures and host-endophyte interaction *in vitro* and *in vivo*. *Canadian Journal of Microbiology* 53(3):380–390
- Verma D, Verma M, Dey M, Jain RK, Wu R (2005) Molecular dissection of the tobacco Rb7 matrix attachment region (MAR): Effect of 5' half on gene expression in rice. *Plant Science* 169(4):704–711
- Videira SS, Simoes de Araujo JL, da Silva Rodrigues L, Baldani VLD, Baldini JI (2010) Occurrence and diversity of nitrogen-fixing *Sphingomonas* bacteria associated with rice plants grown in Brazil. *FEMS Microbiology Letters* 293(1):11–19
- Watson SA (1982) Maize: amazing maize. General properties. In: Wolf IA (ed) *CRC Handbook of Processing and Utilisation in Agriculture*, vol II, Part 1. Plant Products, General Properties. CRC Press Inc, Florida, p. 3–29
- Watson SA (1987) Structure and Composition. In: Watson SA, Ransted PE (eds) *Corn: Chemistry and Technology*. American Association of Cereal Chemists, Inc, Minnesota, p. 53–82
- White PJ, Pollak LM (1995) Corn as a food source in the United States: Part II. Processes, products, composition, and nutritive values. In: *Cereal Foods World* 40. p. 756–762
- Wright, T. R., Lira, J. M., Merlo, D. J., Hopkins, N. (2009) Novel herbicide resistance genes. Patent US 2009/0093366 A1
- Wright TR, Shan G, Walsh TA, Lira JM, Cui C, Song P, Zhuang M, Arnold NL, Lin G, Yau K, Russell SM, Cicchillo RM, Peterson MA, Simpson DM, Zhou N, Ponsamuel J, Zhang Z (2010) Robust crop resistance to broadleaf and grass herbicides provided by aryloxyalkanoate dioxygenase transgenes. *Proceedings of the National Academy of Sciences* ePub, doi:101073/pnas.1013154107

Yanisch-Perron C, Vieira J, Messing J (1985) Improved M13 phage cloning vectors and host strains: nucleotide sequences of the M13mp18 and pUC19 vectors. *Gene* 33(1):103–119

Zipper C, Nickel K, Angst W, Kohler HP (1996) Complete microbial degradation of both enantiomers of the chiral herbicide mecoprop [(RS)-2-(4-chloro-2-methylphenoxy)propionic acid] in an enantioselective manner by *Sphingomonas herbicidovorans* sp. nov. *Applied and Environmental Microbiology* 62(12):4318–4322